

MACHINES

APH SERIES

APH HYDROSTATIC
VIBRATORY PLATES



AMMANN

THE RIGHT FIT ON YOUR JOBSITE

AMMANN APH HYDROSTATIC VIBRATORY PLATES

Ammann APH Hydrostatic Vibratory Plates deliver compaction power and productivity to jobsites. The plates have drive and climbing power, even when working in cohesive soils. The compactors enable smooth directional changes and easy operation, even by the inexperienced. Operators can adjust to jobsite conditions by simply regulating the engine revolutions.

Lowest hand-arm-vibrations to the operator are one of the key features of these plates, enabling operators to work long shifts without the need of documentation for operator safety regulations.



APH 5020

Weight: 367–400 kg
Working width: 450–750 mm
Centrifugal force: 50 kN



APH 6020

Weight: 482–518 kg
Working width: 550–850 mm
Centrifugal force: 60 kN



APH 1000 TC

Weight: 715–747 kg
Working width: 696 mm
Centrifugal force: 63 kN



APH 5030

Weight: 375–408 kg
 Working width: 450–750 mm
 Centrifugal force: 50 kN



APH 6530

Weight: 491–527 kg
 Working width: 550–850 mm
 Centrifugal force: 65 kN



APH 100-20

Weight: 675–727 kg
 Working width: 650–950 mm
 Centrifugal force: 80 kN



APH 110-95

Weight: 778–830 kg
 Working width: 650–950 mm
 Centrifugal force: 110 kN



YOUR BENEFITS AT A GLANCE

WHAT SETS AMMANN HYDROSTATIC VIBRATORY PLATES APART?

HYDROSTATIC DRIVE

The APH line features a fully hydrostatic system that doesn't require V-belts or a centrifugal clutch and the maintenance that goes with them. A hydraulic motor drives the eccentric shafts. An orbitrol controls the adjustment of the centrifugal weights, allowing a smooth change of direction.

LONG LIFE

The plates are built to last, starting with strict manufacturing standards in Germany. On the jobsite, a sturdy casing shields the engine and hydrostatic components from dirt and debris. The foldable casing provides easy access for maintenance, essential in ensuring all fluids are regularly checked and refilled.

HIGHEST QUALITY STANDARDS

The performance of APH plates helps meet all jobsite quality standards. The plates deliver compaction, even in tough-to-reach places. Extensions ensure you have the perfect fit for the conditions, helping you deliver the desired quality. ACE, Ammann's compaction control system, ensures quality.

OPERATOR SAFETY

Even the inexperienced can quickly learn the operation and management of Ammann APH plates. The optional dead-man's handle automatically stops the machine when the operator releases the handle. Sound levels also are lower than those on competitive models.



LOWEST HAND ARM VIBRATION

The standard hand guide for APH is vibration isolated to keep hand-arm-vibration to a minimum.

With emissions of less than 2.5 m/s^2 (excl. APH 100-20) enable the APH vibratory plates long workshifts without stress to the operator or the need of documentation for operator safety reasons.

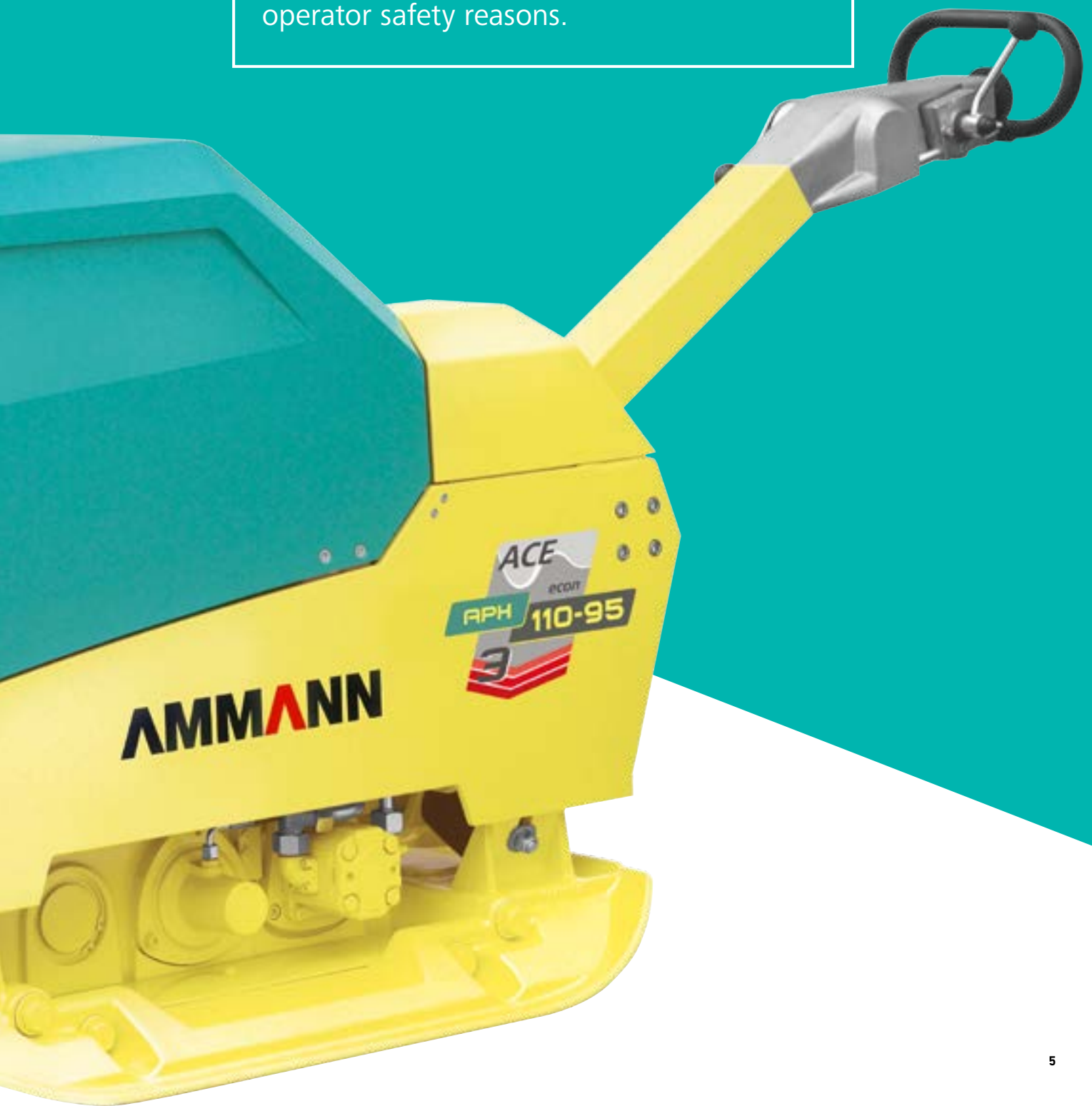

TECHNICAL SOLUTIONS FOR YOUR JOBSITE

CUSTOMISED FOR YOUR NEEDS

Quality and productivity need to be built into every machine. Ammann machines have both, and they also are easy to operate.



DEAD-MANS HANDLE

Electronic sensors automatically stop the machine when the operator loses its grip. The plate remains in idle and only resumes working when the operator regains hold of the handle, meaning the tiresome process of restarting the engine is avoided every time the handle is released. The sensors also allow the use of working gloves.



E-START

E-Start versions fire up the plate compactor. E-Start is a convenience for experienced operators and also helps new operators get up and running effortlessly.



EXTENSION PLATES

Extension plates in 2 different sizes expand the compaction surface area and add productivity. Adding an extension requires the adjustment of only 4 screws per side and can be quickly accomplished on the jobsite.



VULCOLLAN MAT

The mats are attached to the plates and prevent cracking and breaking of paving stones and other sensitive materials while still delivering the required compaction power. Installation of the vulcollan mats is easy and can be done directly on site.

ACE COMPACTION EXPERT

BIG TECHNOLOGY IN A SMALL PACKAGE

APH Hydrostatic Vibratory Plates can be equipped with the well-known Ammann Compaction Expert (ACE), an automated compaction measurement and control system.

The ACE system on the vibratory plates utilises the well developed technology used in Ammann's heavy compaction machines for years. It provides operators with an accurate indication of soil stiffness and whether desired compaction has been achieved.

The benefits of ACE technology are significant.

1. It can reduce the number of passes a plate compactor makes, therefore delivering savings on fuel, labour and machine wear.
2. ACE helps ensure proper compaction is achieved and prevents costly rework.
3. It extends the life of the compacted material – and structures placed on top of it – by providing a homogenous surface without weak spots.

AMMANN PLATE COMPACTORS FEATURE 2 ACE TECHNOLOGIES TO CHOOSE:



ACE^{econ}

- Relative compaction measuring device
- Provides continuous information about compaction levels
- Evaluates when maximum compaction has been reached



ACE^{force}

- Profiles measurement
- Precisely measures and evaluated material stiffness
- Operator guiding function shows compaction progress



“ Hand-arm-vibrations
of less than 2.5 m/s^2
preserve the operator
and enable long working
shifts.”



APH 5020

A TRUSTED COMPACTOR

The APH 5020 Hydrostatic Plate Compactor features a two-shaft exciter system that packs powerful compaction forces. This machine is highly reliable and trusted in the marketplace because of its robust design and long component life.

This hydrostatic plate weighs from 367 kg to 400 kg. It can be operated easily and comfortably, even in tight areas, and works well around obstacles such as columns and in cohesive materials. The machine also is smooth when changing directions.

APH 6020

TRUSTED AND RELIABLE

The APH 6020 is a heavier version of the popular APH 5020. Weighing from 482 kg to 518 kg, the APH 6020 also features a two-shaft exciter system and the efficient and powerful compaction it brings.

The machine is highly reliable and trusted in the marketplace because of its robust design and long component life. The plates can be operated easily and comfortably, even in tight areas, and work well around obstacles such as columns and in cohesive materials. The machine also is smooth when changing directions.



MACHINE HIGHLIGHTS

- Hydraulic pump for hydrostatic drive and responsive steering; no V belt required
- Air-cooled Hatz diesel engine with low oil pressure protection system
- Easy access to all service points
- Optimised base plate for well-balanced operation
- Plates can be equipped with the Ammann ACE^{econ}, a compaction control system developed for larger Ammann compactors and now adjusted to fit the APH line
- Extension plates enable a wide field of applications with a variety of working widths



APH 1000 TC

THE REMOTE CONTROLLED COMPACTION PLATE

The APH 1000 TC is an IR remote-controlled hydrostatic plate that can go where others can't.

The IR remote abilities ensure operation under the toughest conditions – and in the tightest spaces and deepest trenches. The operator is able to steer the vibratory plate from a safe distance with a remote control or cable remote.

The APH 1000 TC achieves high compaction results even in the deepest trenches and most impassable areas thanks to its high performance and to the compact machine design. It is very responsive to the operator's commands.

Safety is built into the machine, including an emergency stop on the remote control. The vibratory plate automatically shuts off if a connection to the operator is lost or if the machine comes within 2 m of the operator.

There are several benefits using the remote control machine APH 1000 TC. There are no emissions for the operator in the trench. Also the steering can be done in safe distance. Furthermore canal building and other dangerous areas can be compacted without any risks for the operator. In case of any reasons the machine can also be controlled with a long cable.

The remote control works with two sticks for the directions so it is possible to guide the machine easily. The red button on the remote control is the emergency stop button which stops the machine immediately. The machine automatically stops when the operator is closer than two meters or when the machine is out of vision of the remote control and does not receive an infrared signal. Also there is a stick to start and end the vibration. The remote control will be charged by sunlight as it has got two solar panels. This works even on a cloudy day and within in a few minutes in case it was fully discharged the operator can start the shift.

MACHINE HIGHLIGHTS

- Hydrostatic twin-shaft exciter system
- Air-cooled Hatz diesel engine with low oil pressure protection system
- Hydraulic pump for hydrostatic drive and steering; no V belt
- Robust IR remote control with solar panels for long work intervals
- Easy access to all service points
- Optimised base plate for well-balanced operation



“With its large range of vibratory plates Ammann offers you the suitable machine designated to your needs.”

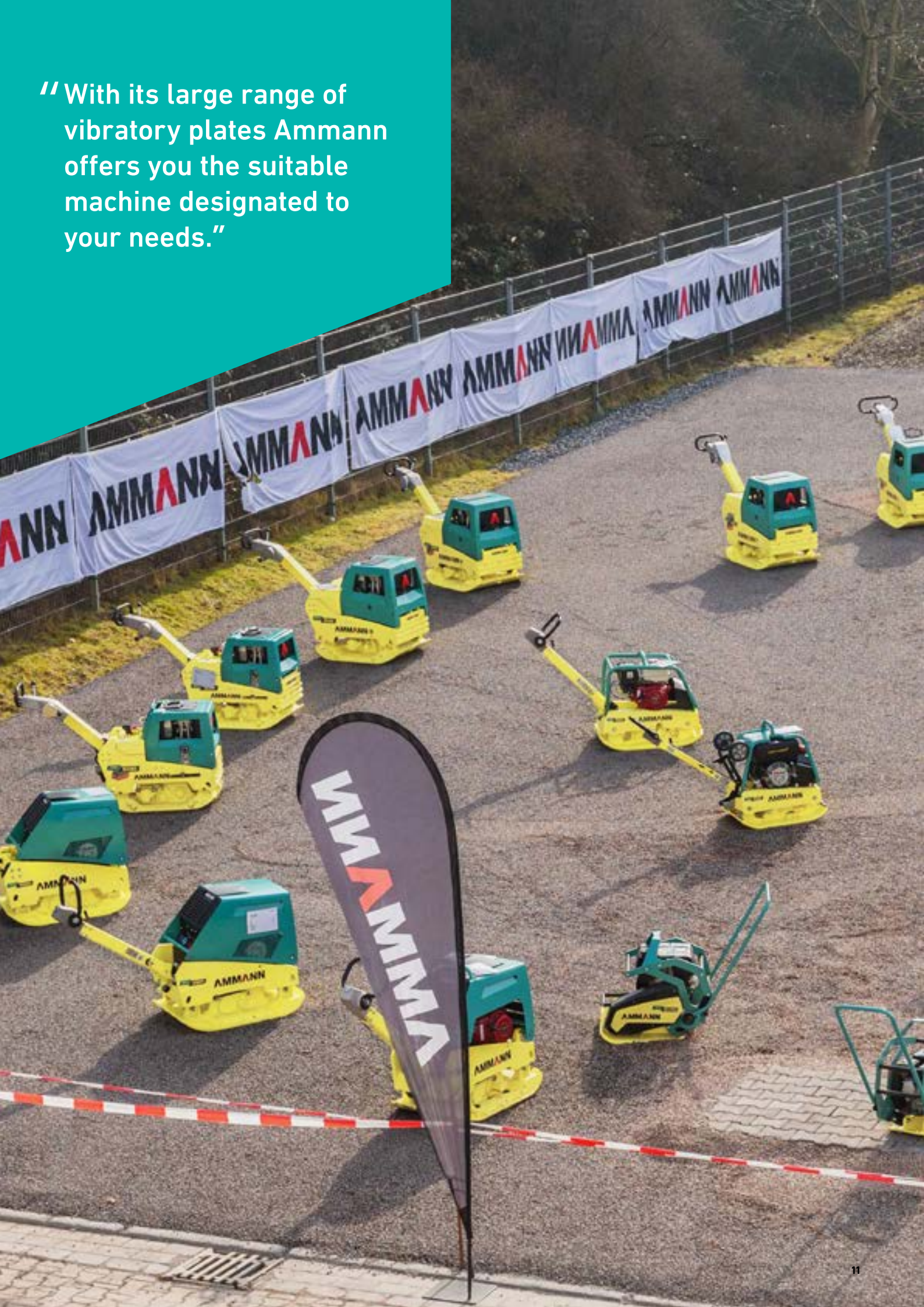

“Ammann triple shaft exciter system provides unmatched compaction results to the APH Vibratory plates.”



AMMANN TRIPLE SHAFT EXCITER UNIT

MARKET LEADING TRIPLE SHAFT EXCITER SYSTEM GIVES AMMANN APH VIBRATORY PLATES THE EXTRA EDGE WHEN CONDITIONS GET TOUGH

Ammann remains the technological leader in plate compaction with its patented triple-shaft exciter system.

The system keeps plate movement consistent, which in turn enables smooth travel – even through heavy, cohesive soils – and helps effortlessly overcome steep grades. APH machines are impressive climbers and can even do so while backfilling saturated areas – work that can leave competitive products at a standstill.

The success of the plates starts with the use of the third shaft. With twin-shaft systems, plates can rock back and forth and their leading edge can turn downward and become stuck, particularly in saturated materials.

With the Ammann exciter system, the third shaft prevents that back-and-forth movement by providing another force. This creates more consistent drive of the plates and keeps them even, steady and above the surface – even on saturated jobsites.

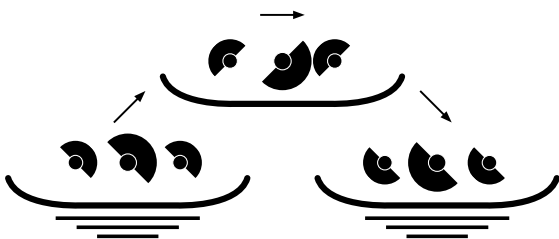

APH 5030

COMPACTION POWER COMBINED WITH CLIMBING ABILITIES

This hydrostatic vibratory plate compactor distinguishes itself with its high compaction power and climbing ability.

The plates are equipped with the market-leading Ammann three-shaft exciter system, which not only enables performance and climbing ability, but also makes the machines more responsive and easier to turn.

The APH 5030 weighs from 375 kg to 408 kg. Several options, such as an electric starter, extension plates, operation hour meter and dead man's handle allow for customisation to make the plate fit your particular needs.

APH 6530

CLIMBING AND PERFORMING

The APH 6530 is another powerful performer that delivers compaction force every step of the way.

The machine, equipped with the market-leading Ammann three-shaft exciter system, which not only enables performance and climbing ability but also makes the machines more responsive and easier to turn.

The APH 6530 weighs from 491 kg to 527 kg. Several options, such as an electric starter, extension plates, operation hour meter and dead man's handle allow for customisation to make the plate fit your particular needs.

The optional ACE^{force} compaction measuring system is another key tool many contractors utilise in efforts to achieve thorough, efficient compaction results.



MACHINE HIGHLIGHTS

- Hydrostatic three-shaft exciter system for power and climbing
- Air-cooled Hatz diesel engine with low oil pressure protection system
- Hydraulic pump for hydrostatic drive and steering; no V belt required
- Ergonomic guide handle with hydrostatic orbital steering
- Easy access to all service points
- Optimised base plate for well-balanced operation
- Plates can be equipped with the Ammann ACE^{econ}, a compaction control system developed for larger Ammann compactors and now adjusted to fit the APH line



APH 100-20

A HEAVY HITTER

The weight of the APH 100-20 combines with the industry-leading three-shaft exciter system to provide performance, climbing ability and responsiveness.

The vibratory plate weighs from 675 kg to 727 kg. Several options, such as extension plates, operation hour meter and dead man's handle allow for customisation to make the plate fit your particular needs.

The optional ACE^{force} compaction measuring system is another key tool many contractors utilise in efforts to achieve thorough, efficient compaction results.



MACHINE HIGHLIGHTS

- Electric starter
- Hydrostatic three-shaft exciter system for power and climbing
- Air-cooled Hatz diesel engine with low oil pressure protection system
- Hydraulic pump for hydrostatic drive and steering; no V belt required
- Ergonomic guide handle with hydrostatic orbital steering
- Easy access to all service points
- Optimised base plate for well-balanced operation
- Available with ACE^{force} intelligent compaction measuring system or with ACE^{econ}, compaction control system

APH 110-95

THE SUPERIOR VIBRATORY PLACE COMING FROM AMMANN

The APH 110-95 is the premiere vibratory plate compactor in the Ammann lineup.

From 778 kg to 830 kg it is the heaviest plate. With its high compaction capabilities the machine matches the output of a 7 t. soil compactor.

A powerful Kubota diesel engine, which also meets strict emissions standards provides sufficient power for all tasks.

The vibratory plate features the Ammann three-shaft exciter system that enables compaction and climbing ability while making the machine easy to handle.

The APH 110-95 is built for professionals with most features – including the ACE^{econ} compaction measuring system – standard configuration.



MACHINE HIGHLIGHTS

- Hydrostatic three-shaft exciter system for power and climbing
- Water-cooled Kubota diesel engine with low oil pressure protection system
- Hydraulic pump for hydrostatic drive and steering; no V belt required
- Ergonomic guide handle with hydrostatic orbital steering
- Easy access to all service points
- Optimised base plate for well-balanced operation
- ACE^{econ} compaction measuring system included
- Electric start
- Working-hour meter
- Emergency stop on guide handle

“The APH 110-95 is a vibratory plates for professionals – with plenty of compaction power to manage hard work on a daily basis.”



SPECIFICATION

APH VIBRATORY PLATES

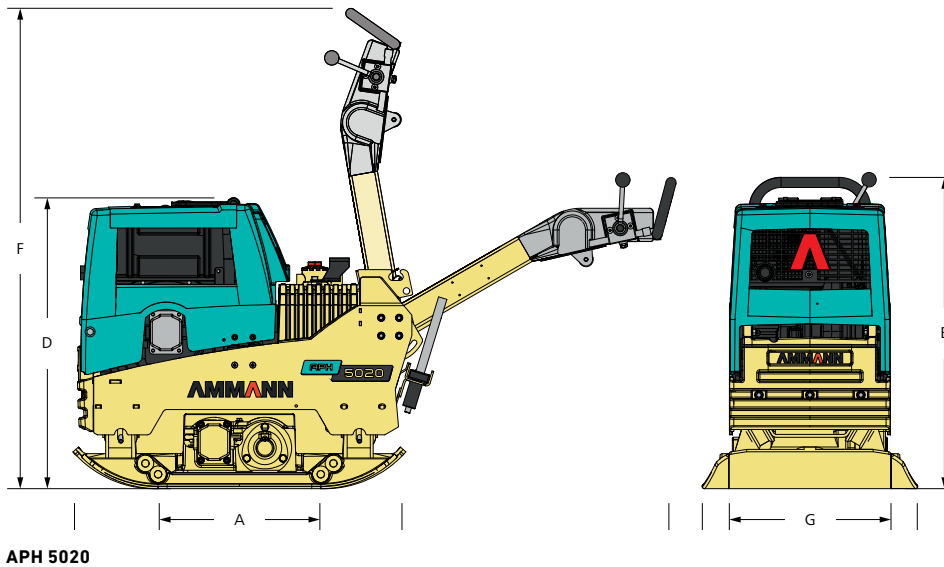

WEIGHT & DIMENSIONS

	APH 5020	APH 6020
MACHINE WEIGHT BASIC UNIT	367 kg	482 kg
WITH EXTENSION PLATES 75 MM	388 kg	506 kg
WITH EXTENSION PLATES 150 MM	400 kg	518 kg
A BASE PLATE LENGTH	450 mm	470 mm
B MACHINE LENGTH	900 mm	930 mm
C WITH HANDLE	1600 mm	1840 mm
D MACHINE HEIGHT	775 mm	870 mm
E HANDLE HEIGHT (WORK)	1000 mm	1000 mm
F HANDLE HEIGHT (TRANSPORT)	1380 mm	1500 mm
G MACHINE WIDTH	450 mm	550 mm
H WITH EXTENSION PLATES	600/750 mm	700/850 mm

ENGINE

	Hatz Supra 1D50S	Hatz Supra 1D81S
ENGINE	Hatz Supra 1D50S	Hatz Supra 1D81S
FUEL	Diesel	Diesel
ENGINE OUTPUT	9.5 HP / 7 kW	13.7 HP / 10 kW
AT RPM	3100 rpm	3000 rpm
FUEL CONSUMPTION	1.7 l/h	2.5

COMPACTION FORCES

MAX. VIBRATION FREQUENCY	65 Hz	69 Hz
MAX. CENTRIFUGAL FORCE	50 kN	60 kN
WORKING SURFACE BASIC UNIT	594 m ² /h	925 m ² /h
WITH EXTENSIONS	792/990 m ² /h	1260 m ² /h / 1430 m ² /h
MAX. COMPACTION DEPTH *	70 cm	80 cm

MISCELLANEOUS

OPERATING SPEED	22 m/min	28 m/min
TANK CAPACITY	5 l	7 l
GRADEABILITY	36 %	36 %
MAX. INCLINE TO ALL SIDES	30°	30°

*depending on ground conditions

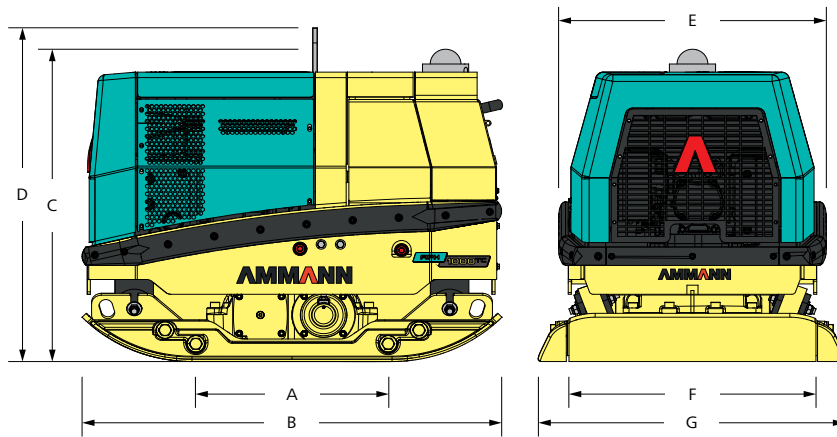

APH 1000TC

WEIGHT & DIMENSIONS

APH 1000 TC

MACHINE WEIGHT BASIC UNIT	715 Kg
WITH EXTENSION PLATES 75 MM	747 Kg
A BASE PLATE LENGTH	520 mm
B MACHINE LENGTH	1090 mm
C MACHINE HEIGHT	845 mm
D MACHINE HEIGHT (W. TRANSPORT HOOK)	910 mm
E MACHINE WIDTH	696 mm
F BASE PLATE WIDTH	650 mm
G WITH EXTENSIONS	800 mm

ENGINE

ENGINE	Hatz 1D90V
FUEL	Diesel
ENGINE OUTPUT	14.8 HP / 10.9 kW
AT RPM	3000
FUEL CONSUMPTION	2.5 l/h

COMPACTION FORCES

MAX. VIBRATION FREQUENCY	46 Hz
MAX. CENTRIFUGAL FORCE	63 kN
WORKING SURFACE BASIC UNIT	1090 m ² /h
WITH EXTENSIONS	1350 m ² /h
MAX. COMPACTION DEPTH*	90 cm

MISCELLANEOUS

OPERATING SPEED	28 m/min
TANK CAPACITY	10 l
GRADEABILITY	35 %
MAX. INCLINE TO ALL SIDES	25°

*depending on ground conditions

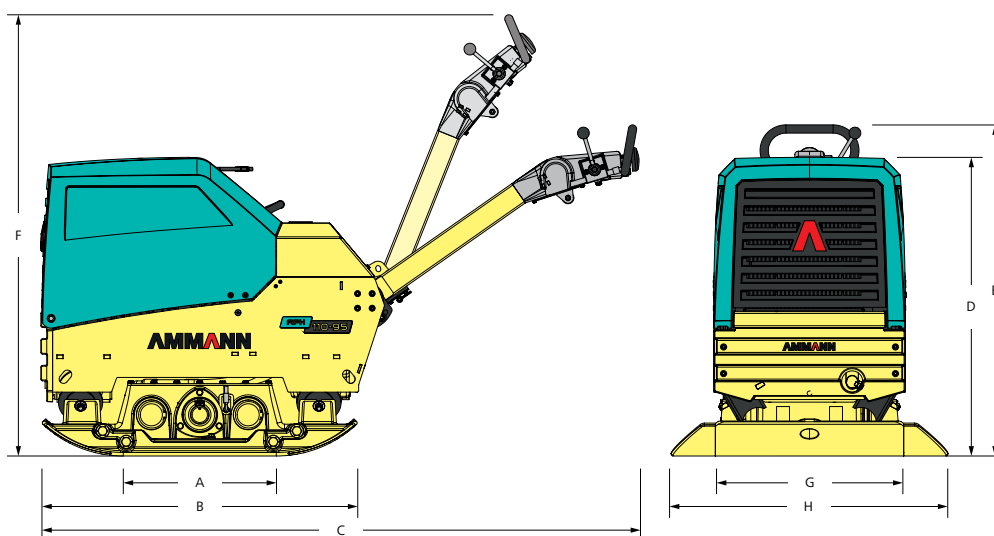

APH 110-95

WEIGHT & DIMENSIONS

	APH 5030	APH 6530	APH 100-20	APH 110-95
MACHINE WEIGHT BASIC UNIT	375 kg	491 kg	675 kg	778 kg
WITH EXTENSION PLATES 75 MM	396 kg	515 kg	704 kg	807 kg
WITH EXTENSION PLATES 150 MM	408 kg	527 kg	727 kg	830 kg
A BASE PLATE LENGTH	450 mm	470 mm	520 mm	520 mm
B MACHINE LENGTH	900 mm	930 mm	1070 mm	1070 mm
C WITH HANDLE	1600 mm	1840 mm	1965 mm	1965 mm
D MACHINE HEIGHT	775 mm	870 mm	900 mm	1000 mm
E HANDLE HEIGHT (WORK)	1000 mm	1000 mm	1000 mm	1200 mm
F HANDLE HEIGHT (TRANSPORT)	1500 mm	1500 mm	1500 mm	1600 mm
G MACHINE WIDTH	450 mm	550 mm	650 mm	650 mm
H WITH EXTENSION PLATES	600/750 mm	700/850 mm	800/950 mm	800/950 mm

ENGINE

ENGINE	Hatz Supra 1D50S	Hatz 1D81S	Hatz 1D90S	Kubota D1105
FUEL	Diesel	Diesel	Diesel	Diesel
ENGINE OUTPUT	9.5 HP / 7 kW	13.7 HP / 10.1 kW	14.8 HP / 10.9 kW	23.8 HP / 17.5 kW
AT RPM	3100 rpm	3000 rpm	3000 rpm	3000 rpm
FUEL CONSUMPTION	1.7 l/h	2.5 l/h	2.5 l/h	4 l/h

COMPACTION FORCES

MAX. VIBRATION FREQUENCY	65 Hz	55 Hz	40 Hz	48 Hz
MAX. CENTRIFUGAL FORCE	50 kN	65 kN	100 kN	110 kN
WORKING SURFACE BASIC UNIT	594 m ² /h	1056 m ² /h	1090 m ² /h	1400 m ² /h
WITH EXTENSIONS	792/990 m ² /h	1344/1632 m ² /h	1350/1600 m ² /h	1720/2050 m ² /h
MAX. COMPACTION DEPTH *	70 cm	90 cm	100 cm	110 cm

MISCELLANEOUS

OPERATING SPEED	22 m/min	32 m/min	28 m/min	36 m/min
TANK CAPACITY	5 l	7 l	10 l	16.5 l
GRADEABILITY	36 %	36 %	36 %	35 %
MAX. INCLINE TO ALL SIDES	30°	30°	30°	30°

*depending on ground conditions

“The QR Code on each machine leads to the Ammann Service App providing further technical information and videos.”



TRAINING

ENHANCE YOUR PERFORMANCE

The Ammann International Training Centre in the Czech Republic is our training headquarters.

If you are not able to visit the International Training Centre, Ammann will bring the training to your business or even a jobsite of your choosing.

MACHINE TRAINING MODULES

Modules help you organise your team's training efforts. For example, you can have comprehensive lessons that put you on the path to expertise regarding a single machine. Or, if you prefer, your crew can instead broaden its general knowledge.

And if you want to become an expert on the entire product line, the modules can accommodate that, too.



MAIN COURSES

These are the most frequently requested lessons and focus on one machine line.

SUB COURSES

These courses focus on a single machine and typically run for 2 days, allowing a second (or even third) such course to be taken during a week at the training centre.

PRODUCT COURSES

Important information regarding Ammann compaction machines is at the core of these classes. The training includes correct operation and basic maintenance.

ADMINISTRATIVE COURSES

Participants in this training learn effective utilisation of warranty claims, spare parts purchase orders, training, requests for technical support and service tips. Those who take these classes will learn to use all Ammann technical publications and administration tools.

COMMISSIONING COURSES

In this training, participants learn maintenance and proper methods for organising a commissioning of Ammann compactors and asphalt pavers.

INTELLIGENT COMPACTION COURSES

Participants learn about the ACE^{force}, ACE^{pro} and ACE^{plus} systems used in Ammann machines. Those who take the class will learn to properly operate, maintain, diagnose and repair ACE systems. The offerings include ACE iii System for Soil Compactors, which is focused on ASC rollers, and ACE iii System for Asphalt Compactors, which discusses systems on ARP 95, ARX 90 and ARX 110.

SERVICE

A NETWORK TO SUPPORT YOU

No matter where you are, Ammann-trained technicians and parts are nearby. Ammann dealers provide well-trained service technicians who can help you, whether it's an emergency or time for preventive maintenance. The vast Ammann network ensures there is a nearby technician who understands your language and your technical needs. Parts availability and ease of ordering are always Ammann priorities.

SERVICE VIDEOS

Sometimes a video tells the story best. That's why you'll find a variety of service videos that walk you through service and maintenance processes.

Many maintenance kits feature QR codes that link to videos with helpful demonstrations that walk you or your technician through the process. The videos tell the story without dialogue so customers anywhere in the world can understand.

HOTLINE SUPPORT

Ammann experts are ready to answer your technical questions 24 hours a day, seven days a week. The hotline team is highly trained and experienced. Representatives can talk you through the challenges – in various languages – to help keep your machine productive.



“Ammann-trained technicians, parts availability and ease of ordering are Ammann priorities. For more information visit www.ammann-group.com.”

SPARE PARTS

You can only earn money when your equipment is working. That's why Ammann does everything possible to ensure you have the parts where and when you need them. Those efforts include easy online ordering to avoid confusion and enable tracking, and efficient logistics and availability to help parts reach you quickly.



WEARING KITS

Some machines handle abrasive materials in demanding applications. While wear is inevitable, downtime can be limited. Wearing kits make replacement of these parts efficient and cost-effective. All the necessary parts – big and small – are in a single box to keep you organised and efficient and to ensure the machines are quickly back up and running.

MAINTENANCE KITS

Preventive maintenance is crucial to efficient operation and service life of machines. The easier the maintenance, the more likely it is to be completed. Maintenance kits make the upkeep simple. Parts associated with a particular maintenance process are in a single box with a single part number.

REPAIR KITS

Repair kits are available for more in-depth repairs, typically those that require the machine to be transported from the jobsite. The repair kits feature all parts – from the biggest components to the tiniest nut and bolt – needed for a particular repair. The kits ensure everything is there when you need it, thereby preventing the absence of a single, small part from keeping a productive machine from working.

EMERGENCY KITS

Emergency kits prevent little frustrations from becoming bigger issues that can shut down a machine and even a jobsite. These kits include parts such as switches, fuses and valve coils that are simple and fast to change yet still can cause significant problems if not operating properly. The kits easily fit in the trunk or bed of a vehicle so they're on hand when needed. A crew-member with a bit of technical knowledge can handle this work on the jobsite. These repairs take 2 hours or less.

PROSPECT WITH ALL KITS

We have a prospect with all kits, and their part numbers are available for you. Just contact your parts consultant and have a digital or hardcopy sent to you.

“Service kits ensure that every part is there when you need it, while emergency kits prevent a little challenge from becoming a big one.”



For additional product information
and services please visit:
www.ammann-group.com

