



Bobcat[®]

One Tough Animal.

COMPACT WHEEL LOADERS

L85

🌐 Europe



INTRODUCTION

ONE TOUGH ANIMAL



BOBCAT'S HISTORY

In 1958, Melroe Manufacturing Company introduced a compact front-end loader that evolved quickly into the M400, the world's first true skid steer loader. The company soon adopted what became the world-famous 'Bobcat' brand – and its success paved the way for the global compact equipment industry we know today.

IN EUROPE, FOR EUROPE

Compact wheel loaders are developed and manufactured at the same premises as other legendary Bobcat products.



BOBCAT TODAY

Bobcat loaders reshaped the agriculture and construction industries with a solution that is compact, maneuverable, productive and tough. Today, with the largest portfolio of loaders on the market, we continue the spirit of this pioneering product.

OUR MISSION

We empower operators to accomplish more, while working in the toughest conditions and tightest situations. When our customers have the will, we provide the way.



DESIGNED AROUND THE WAY YOU WORK

▶ POWERFUL YET ACCESSIBLE

With a stellar combination of high power, intuitive controls, operator comfort and ease of use, Bobcat's compact wheel loader is perfect for a multitude of tasks, whatever your business.



Fully glassed doors for best visibility all around the machine

ROPS/FOPS level II protection

LED work lights

Road package allows driving legally on the street

5-inch LCD display

Large mirrors for the best rear visibility

Bucket level indicator

Pressurized heated cab and air conditioning

LED road lights

Low front window corners for great visibility

Automatic ride control provides lift arms dampening effect for best driving comfort

Rear-view camera

Industry standard hydraulic coupling system with ability to use the Bob-Tach™ adapter to take advantage of approved advanced Bobcat attachments

Automatic parking brake

Handle even the most complex attachments thanks to Advanced Attachment Controls, 100 l/min high flow and wide selection of attachments. **P.13**

2 steps to get in and out of the cab comfortably

Switch between work and travel modes thanks to the 2 Speed feature (up to 30 km/h in travel mode)

Wide range of buckets for all loading applications

Selection of tire sizes to match your needs



▶ ROCK-SOLID PERFORMANCE

Powerful engine, wide attachment selection, and a comfortable cab. With Bobcat's compact wheel loader, you complete every job efficiently



▶ SMART AND INTUITIVE

Get started in seconds thanks to simple and intuitive controls. Even less experienced operators can get to work fast and with confidence.



▶ FIRST-CLASS COMFORT

Stay comfortable thanks to a luxurious seat and 2-way adjustable steering column, while enjoying great visibility with a fully glass door.



▶ RELIABLE SUPPORT

Bobcat has your back with an extensive dealer network, a single service point for machine and engine and remote monitoring.

PERFORMANCE



▶ OUTSTANDING PRODUCTIVITY

Equipped with a mighty engine and a powerful high flow option, Bobcat's compact wheel loader features high breakout forces paired with solid stability. Do more, get better results, and grow your business.

▶ TRULY MULTI-PURPOSE

Need to use more than the bucket for a specific job? Choose from a large selection of compatible Bobcat loader attachments and a powerful High Flow option for up to 100 liters/minute.



▶ ONE LESS THING TO WORRY ABOUT

For the first time, 2 handy features from the automotive industry are applied to loaders. With Automatic Parking Brake and Slope Assist, the parking brake is engaged and disengaged seamlessly, just when you expect it.



▶ FULLY IN CONTROL

Let the machine become an extension of your hands thanks to an intelligent, ergonomic and intuitive control scheme, with all functions at your fingertips and many quality-of-life features.



STEP INSIDE



▶ SMOOTH RIDE

Our compact wheel loader was designed to ensure you stay comfortable day after day. The joystick console is firmly connected to the suspension seat - a unique solution on the market. This keeps the joystick stable in your hand and makes the ride easy and smooth, even on uneven terrain.



▶ AT YOUR FINGERTIPS



Everything – from joystick to soft touch button console and jog shuttle wheel – is designed for optimal ease of use and positioned close at hand.

▶ FULLY ERGONOMIC

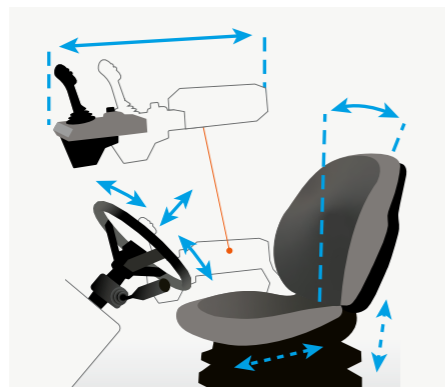

Easily adjust the position of the steering wheel, joystick and seat to what suits you best. Make your loader fit you like a glove.

▶ 5-INCH DISPLAY



Navigated with the jog shuttle, the LCD screen shows vital information and automatically switches to the rear-view camera's feed when reversing.

BUILT TOUGH

▶ LEGACY OF INNOVATION

You'll always find quality materials and sturdy design in your Bobcat machine. This is as true with the time-proven world's most popular skid steer loader as it is with our new compact wheel loader. You can stake your reputation on the durability of our new equipment, built with the same reliable components as other Bobcat machines.

▶ MADE TO KEEP YOU IN THE FIELD

We're continually improving the ease of servicing with features such as battery disconnect and automatic servicing reminders on the screen. Accessing servicing points and battery is easy and integrated greasing points minimize servicing time. If you do need to visit the shop, one service point for both machine and engine will bring you back to the field in no time.



▶ MACHINE IQ

BOBCAT® Machine IQ Wireless Communications enhances the support for your Bobcat machine.

- Durable built-in monitoring electronics
- Data is available to our machine monitoring specialist
- Maintenance is optimized for your business
- Data-driven services maximize uptime

▶ STANDARD WARRANTY

Bobcat Company develops every machine to the highest standards of quality and durability. That's why our standard warranty provides 24 months or 2000 operating hours (whichever occurs first) of coverage.

THERE'S NO TIME FOR DOWNTIME. STAND UP TO THE HARSHTEST CONDITIONS. DAY AFTER DAY.



▶ PROTECTION PLUS EXTENDED WARRANTY

Enjoy total peace of mind with a Protection Plus® extended warranty. Providing the same level of protection as the standard warranty, Protection Plus also reflects different customer needs and expectations by offering a choice of durations and annual operating hours. According to your needs, you can benefit from the coverage for up to 5 years or 6000 engine hours. And Protection Plus is transferrable – so it will likely increase your machine's resale value.



▶ BOBCARE

A long-running machine starts with proper planned maintenance. And it helps protect against repair costs and unplanned failures when you're counting on your machine to work.

- Avoid risk by preventing major repairs and complete failures.
- Accomplish more by reducing downtime and increasing your productivity and profitability.

STANDARD EQUIPMENT & OPTIONS

	L85
PERFORMANCE	
7-pin attachment control	✓
Standard-flow auxiliary hydraulics	✓
High-flow auxiliary hydraulics	•
Advanced Attachment Controls	✓
Automatic ride control	•
Bucket level indicator	✓
ROAD	
Automatic parking brake	✓
2-speed 20 km/h	✓
2-speed 30 km/h	•
Brakes standard	✓
Brakes German (for GSA road homologation)	•
Road package	•
CAB	
12 V power outlet	✓
USB charger	✓
Deluxe pressurized cab with heating	✓
Deluxe pressurized cab with HVAC	•
Cloth suspension seat	✓
Key ignition with password	✓
Heater	✓
HVAC	•
Radio ready	✓
Fire extinguisher	•
WHEELS	
Wheels 335/80 R18	•
Wheels 365/70 R18	•
Wheels 405/70 R18	✓
Wheels 405/70 R20	•
LIGHTS & BEACON	
Work lights LED	✓
Road lights halogen	✓
Road lights LED	•
Beacon	•
MISCELLANEOUS	
Differential lock	✓
Warranty: 24 months or 2000 hours (whichever occurs first)	✓
*Power Quick-Tach	✓
Bobcat Telematics Europe	✓
Wax coat treatment	✓
Backup alarm	•
Rear-view camera	✓

• = option ✓ = standard

*can add Bob-Tach™ adapter

PERSONALIZE YOUR MACHINE

Sometimes, we all want to add a specific functionality or a personal touch to the machine. Choose from a list of comprehensive options and customize your compact wheel loader to your heart's content!



Beacon

Cloth suspension seat

Air conditioning (HVAC)



Rear-view camera

Road lights LED

Work lights LED



Speed 30 km/h

PRECISION OR SPEED? WE SAY BOTH.

CONTROLS TAILORED TO YOUR NEEDS

With traditional controls you can have speed or precision, but not both. Until now. Our revolutionary selectable dual control system allows you to work with just the right precision or speed, when you need it.

STANDARD CONTROLS TO LOAD AND CARRY

You will immediately feel at home during loading and handling applications. Thanks to the standard travel control mode, when the machine speed is controlled by the gas pedal, working with a bucket or a pallet fork is familiar and intuitive. What's more, switching from forward to reverse is now even more convenient than before: the FNR switch, located on the front side of the joystick, stays close to your index finger the whole time.



ADVANCED ATTACHMENT CONTROLS

When using advanced attachments like an angle broom or a snow blower, you can take advantage of Bobcat's unique Advanced Attachment Control mode. At the press of a button, the throttle control dial controls the speed of the attachment alone (independent of the machine's travel speed, which is controlled by the gas pedal with a convenient speed limiter feature). Additionally, you can control up to 4 functions of the attachment thanks to a conveniently located auxiliary control panel.



Auxiliary control panel

Throttle control dial



SPECIFICATIONS

SPECIFICATIONS	
	L85
WEIGHTS	
Operating weight, standard (ISO 6016)	5 091 kg
Shipping weight, standard (ISO 6016)	4 674 kg
Max. front axle load	6 000 kg
Max. rear axle load	6 000 kg
ENGINE	
Model	2.4 L Bobcat engine
Compliance	Stage V
Cooling	Liquid
Fuel	Diesel
Power at 2 600 RPM (ISO 14396)	50.7 kW
HYDRAULIC SYSTEM	
System relief @ quick couplers	20.5 MPa
Auxiliary standard flow	75.40 l/min
Auxiliary high-flow	103.50 l/min
PERFORMANCE WITH BUCKET	
Bucket capacity	0.8 m ³
Bucket range	0.6 - 1.2 m ³
Tipping load, straight (ISO 14397-1)	3 801 kg
Tipping load, articulated at 40° (ISO 14397-1)	3 151 kg
Rated operating capacity (ISO 14397-1)	1 901 kg
Lift breakout force (ISO 14397-2)	48.80 kN
Lift capacity (ISO 14397-2)	36.90 kN
PERFORMANCE WITH PALLET FORK	
Tipping load, straight (ISO 14397-1)	2 910 kg
Tipping load, articulated at 40° (ISO 14397-1)	2 451 kg
DRIVE SYSTEM	
Main drive	Proportionally regulated hydrostatic motor
Transmission	Hydrostatic with electronic regulation
CONTROLS	
Vehicle steering	Machine articulation via hydraulic steering with steering wheel
Travel direction	Travel direction switch (F-N-R) on joystick. Drive pedal in work and travel mode
Machine hydraulics	Dual axis joystick for lift and tilt and auxiliary
Vehicle braking	Combination of integrated 6 wet brake discs in rear axle with hydrostatic braking effect provision

SPECIFICATIONS

DIMENSIONS – BUCKET

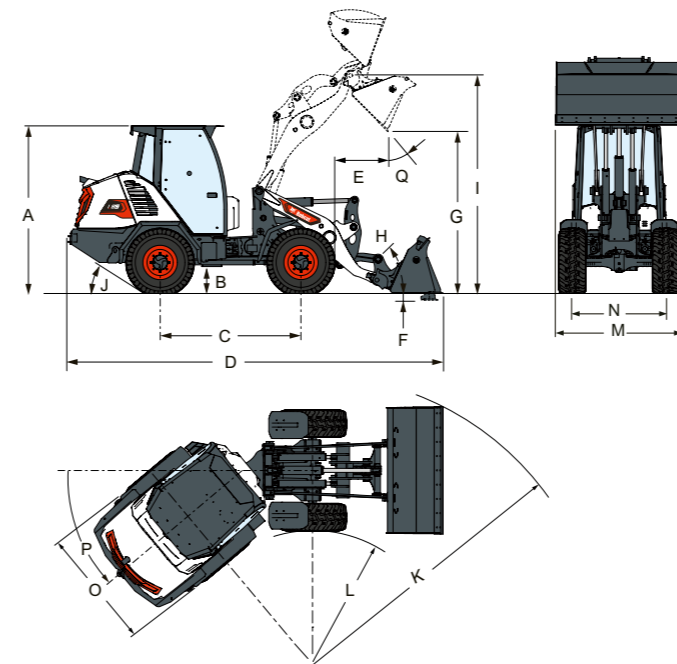

DIMENSIONS – BUCKET	
	L85
A	2 497.7
B	427
C	2 100
D	5 452.7
E	686
F	100
G	2 507.5
I	3 250
J	33.4°
K	3 829.8
L	1 985.6
M	1 900
N	1 393
O	1 800
P	40°
Q	45°

Unit: mm

DIMENSIONS – PALLET FORK

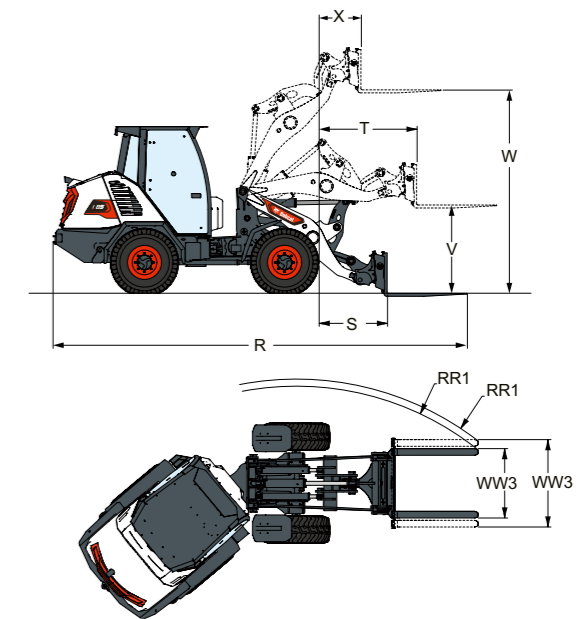

DIMENSIONS – PALLET FORK	
	L85
R	5 979.4
RR1	4 262 - 4 472.6
S	795.9
T	1 277.7
V	1 374
W	3 100
WW3	773.6 – 1 313.6
X	441.9

Certain specification(s) are based on engineering calculations and are not actual measurements. Specification(s) are provided for comparison purposes only and are subject to change without notice. Specification(s) for your individual Bobcat equipment will vary based on normal variations in design, manufacturing, operating conditions, and other factors. Pictures of Bobcat units may show other than standard equipment.

FINANCING OPTIONS

24, 36, OR 48 MONTH FINANCING*

Take advantage of 24, 36 or 48 month financing programs starting from **0% interest** and improve your cashflow. Ask your dealer for the financing offers available.

100 MACHINES / 150 ATTACHMENT FAMILIES / 1 TOUGH ANIMAL



**SKID STEER
LOADERS**



**COMPACT TRACK
LOADERS**

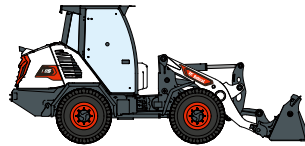

**COMPACT WHEEL
LOADERS**



**SMALL ARTICULATED
LOADERS**

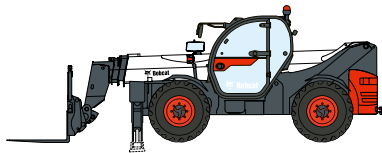

TELEHANDLERS

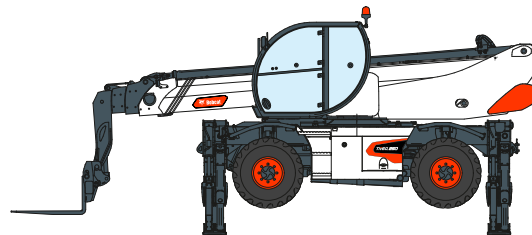

**ROTARY TELESCOPIC
HANDLERS**



**LIGHT COMPACTION
EQUIPMENT**



**MINI TRACK
LOADER**



COMPACT EXCAVATORS

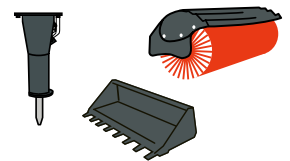

ATTACHMENTS



www.bobcat.com

Bobcat is a Doosan Company. Doosan is a global leader in construction equipment, power & water solutions, engines, and engineering proudly serving customers and communities for more than a century. | Bobcat and the Bobcat logo are registered trademarks of Bobcat Company in the United States and various other countries. ©2021 Bobcat Company. All Rights Reserved.

©2021 BOBCAT B4501892-EN (08-21)



Bobcat®

*Financing options may vary by country and dealer. Always ask your dealer about currently available financing options. Terms and conditions may apply.

Doosan Bobcat EMEA, U Kodelky 1810, 263 12 Dobříš, Czech Republic

