

Ersatzteile

Spare parts
Spares
Pièces de rechange
Piezas de recambio
Ricambi
Peças de reposição
Pieșe de schimb
Náhradných dielov
Reserve dele
Części zamienne



SM 57-2

0401302 - 0401304

Ab Serien-Nr.



Weber Maschinenteknik GmbH

Im Boden 5 – 8 , 10

D- 57334 Bad Laasphe - Rückershausen / Germany

Tel.: +49 (0) 2754 / 398 0

Fax: +49 (0)2754 / 398 101

E-Mail: info@webermt.de

www.webermt.de

BITTE, NOTIEREN SIE SERIENNUMMER UND MOTORNUMMER IHRER MASCHINE:

PLEASE WRITE DOWN SERIALNUMBERS OF MACHINE AND ENGINE:

NOTEZ SVP LE NUMERO DE SERIE ET LE NUMERO DU MOTEUR DE VOTRE MACHINE:

SI PREGA DI ANNOTARE SEMPRE I NUMERI DI SERIE SIA DELLA VS. MACCHINA CHE DEL MOTORE:

MAQUINA: ROGAMOS ANOTEN EL NUMERO DE SERIE Y NUMERO DE MOTOR DE SU MAQUINA:

PROSIMY ZANOTOWAĆ NUMER MASZYNY I SILNIKA

MASCHINE
MACHINE
MACCHINA
MAQUINA
MASZYNA



MOTOR
ENGINE
MOTEUR
MOTORE
SILNIK



ZUR VERMEIDUNG VON FEHLLIEFERUNGEN UND VERZÖGERUNGEN SIND BEI DER BESTELLUNG VON ERSATZTEILEN FOLGENDE ANGABEN UNBEDINGT ERFORDERLICH:

- MASCHINENTYP
- SERIENNUMMER DER MASCHINE
- SERIENNUMMER DES MOTORS (BEI MOTORTEILEN)
- TEILENUMMER
- BESTELLMENGE

TO AVOID ERRORS IN DELIVERY PLEASE STATE THESE PARTICULARS WHEN ORDERING:

- TYPE OF MACHINE
- SERIAL NO. OF MACHINE
- SERIAL NO. OF ENGINE (ON ENGINE PARTS)
- PART-NO.
- QUANTITY REQUIRED

AFIN D'EVITER DES ERREURS DE COMMANDE ET DES RETARDS DE LIVRAISON IL EST NECESSAIRE D'INDIQUER LES CARACTERISTIQUES SUIVANTES:

- TYPE DE MACHINE
- LE NUMERO DE SERIE DE LA MACHINE
- LE NUMERO DE SERIE DU MOTEUR
- LE NUMERO D'IDENTITE DE LA PIECE
- LA QUANTITE SOUHAITEE

ONDE EVITARE DISGUIDI E RITARDI NELLE CONSEGNE DIE RICAMBI SI PREGA DI INDICARE SEMPRE:

- TIPO DELLA MACCHINA
- NUMERO DI SERIE DELLA MACCHINA
- NUMERO DI SERIE DEL MOTORE (SE SI RICHIEDONO PEZZI DEL MOTORE)
- NUMERO D'ORDINE DIE SINGOLI RICAMBI
- QUANTITA

A FI DE EVITAR ERRORES DE ENTREGA, ROGAMOS INDIQUEN LOS SIGUIENTES DATOS CUANDO PASE PEDIDOS DE RECAMBIOS:

- MODELO DE MAQUINA
- NO. DE SERIE DE LA MAQUINA
- NO. DE SERIE DEL MOTOR (EN PIEZAS PARA MOTOR)
- REFERENCIA DEL RECAMBIO
- CANTIDAD PEDIDA

PROSIMY O PODANIE NASTĘPUJĄCYCH DANYCH PRZY SKŁADANIU ZAMÓWIENIA.

- TYP MASZYNY
- NUMER SERYJNY MASZYNY
- NUMER SERYJNY SILNIKA (PRZY CZĘŚCIACH DO SILNIKA)
- NUMER CZĘŚCI ZAMIEWNNEJ
- ZAMAWIANA ILOŚĆ

E 3043-1005

Position Ref.No. Repère Posizione Posicion	Menge Quantity Quantité Quantità Cantidad	Teile-Nr. Part-No. No. Référence Nr. d'Ordine No. Referenzia	Hinweis Hints Indications Indicazione Indicaciones	Position Ref. No. Repère Posizione Posicion	Menge Quantity Quantité Quantità Cantidad	Teile-Nr. Part-No. No. Référence Nr. d'Ordine No. Referenzia	Hinweis Hints Indications Indicazione Indicaciones
1	1	10022567		31	1	20025050	
2	1	10003031					
3	1	20025595					
4	1	10007549					
5	4	20025443					
6	0	25025135	DIN988-PS-20x28x1				
7	2	20025619					
8	2	25049016	DIN440-R9				
9	2	20022012	Tensilock M8x16				
10	1	20025749					
11	0	25025135	DIN988-PS-20x28x1				
12	1	25049016	DIN440-R9				
13	1	20022012	Tensilock M8x16				
14	1	20025050					
15	1	25020017	DIN975-M16x230				
16	1	25031049	DIN917-M16				
18	1	25025190	DIN988-PS-17x24x0,3				
19	1	25025189					
20	1	25031020	DIN936-M16				
21	1	10007542					
22	1	25025305					
23	1	10003030					
24	1	20008041					
25	1	25038016	DIN933-M10x35				
26	3	20008020					
27	1	25031014	DIN985-M10				
28	1	10003903					
29	1	25038034	DIN933-M12x60				
30	1	25031005	DIN934-M12				

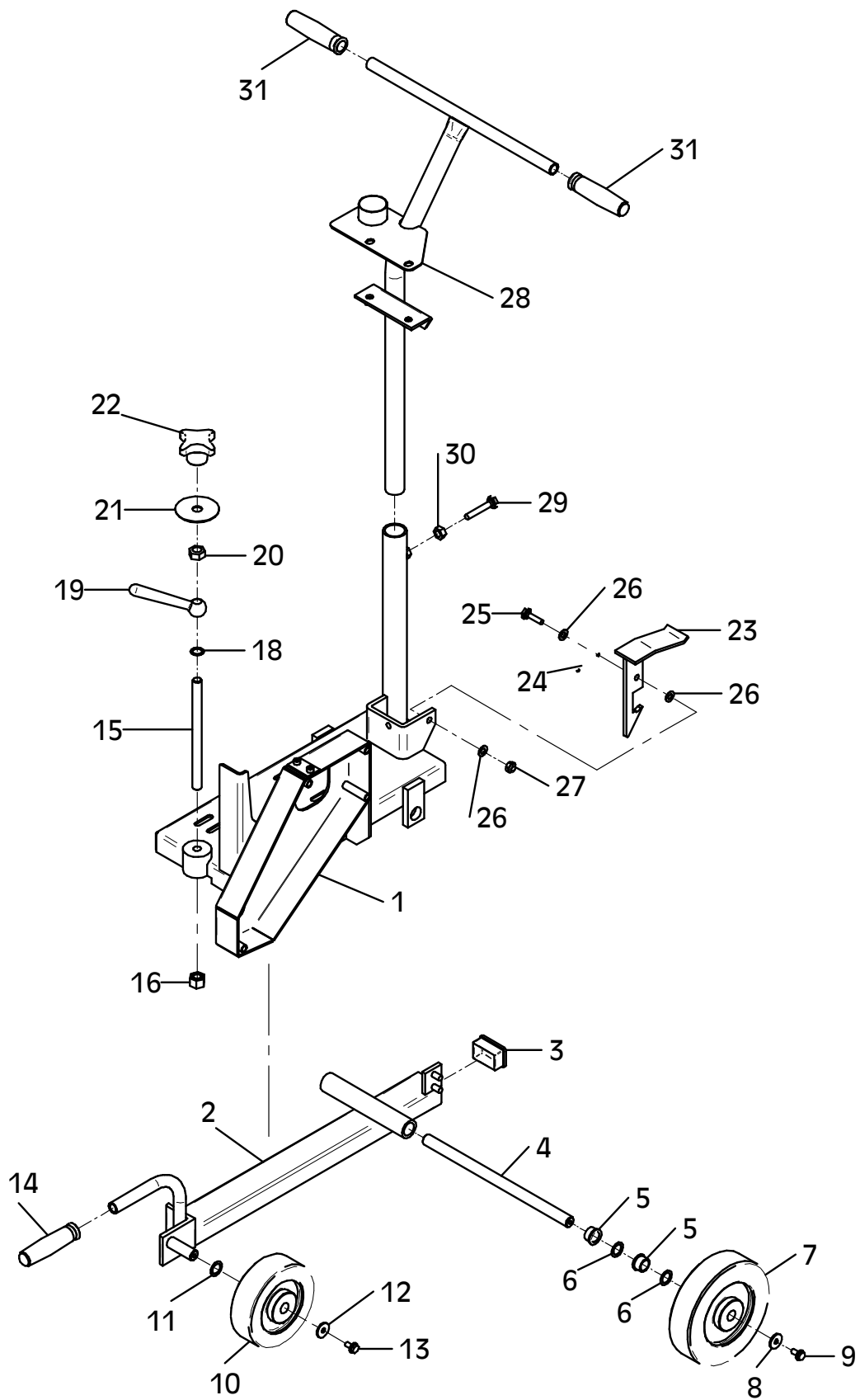

E 3043-1005

E 3047-0610

Position Ref.No. Repère Posizione Posicion	Menge Quantity Quantité Quantità Cantidad	Teile-Nr. Part-No. No. Référence Nr. d'Ordine No. Referenzia	Hinweis Hints Indications Indicazione Indicaciones	Position Ref. No. Repère Posizione Posicion	Menge Quantity Quantité Quantità Cantidad	Teile-Nr. Part-No. No. Référence Nr. d'Ordine No. Referenzia	Hinweis Hints Indications Indicazione Indicaciones
1	1	20001100		30	1	25035009	DIN472-I52x2
2	4	25040068	DIN931-M10x45	31	2	25001037	
3	8	25049020	DIN7349-10,5	32	2	25025176	DIN988-SS-42x52x2,5
4	4	20029001	VSK 10	33	1	25034016	DIN471-A25x1,2
5	4	25031004	DIN934-M10	34	1	10016719	
6	1	10016718		35	1	10008244	
7	1	10005346		36	1	25048012	DIN9021-13x40x3
8	1	25005003	DIN6798-V8,4	37	1	20029004	VSK 12
9	1	25047017	DIN7991-M8x20	38	1	25044075	DIN912-M12x30
10	2	25002022		39	1	25036021	
11	1	10022568		40	1	25038020	DIN933-M12x30
12	3	25044126	DIN912-M8x75	41	1	20029004	VSK 12
13	3	25048002	DIN125-A8,4	42	2	20007036	
14	1	25044060	DIN912-M8x80	43	1	20016357	
15	1	20007001		44	1	10009517	
16	1	25025204		45	1	20025806	
17				46	1	40000260	
18				47	1	30047339	
19	4	20022002	Tensilock M8	48	2	10016341	
20	1	10007356		49	1	21000619	DIN913-M10x10
21	1	10007006					
22	2	25038069	DIN933-M6x25				
23	2	25048001	DIN125-A6,4				
24	2	25031012	DIN985-M6				
25	1	10008027					
26	2	20008013					
27	1	25038020	DIN933-M12x30				
28	1	25031015	DIN985-M12				
29	1	10007354					

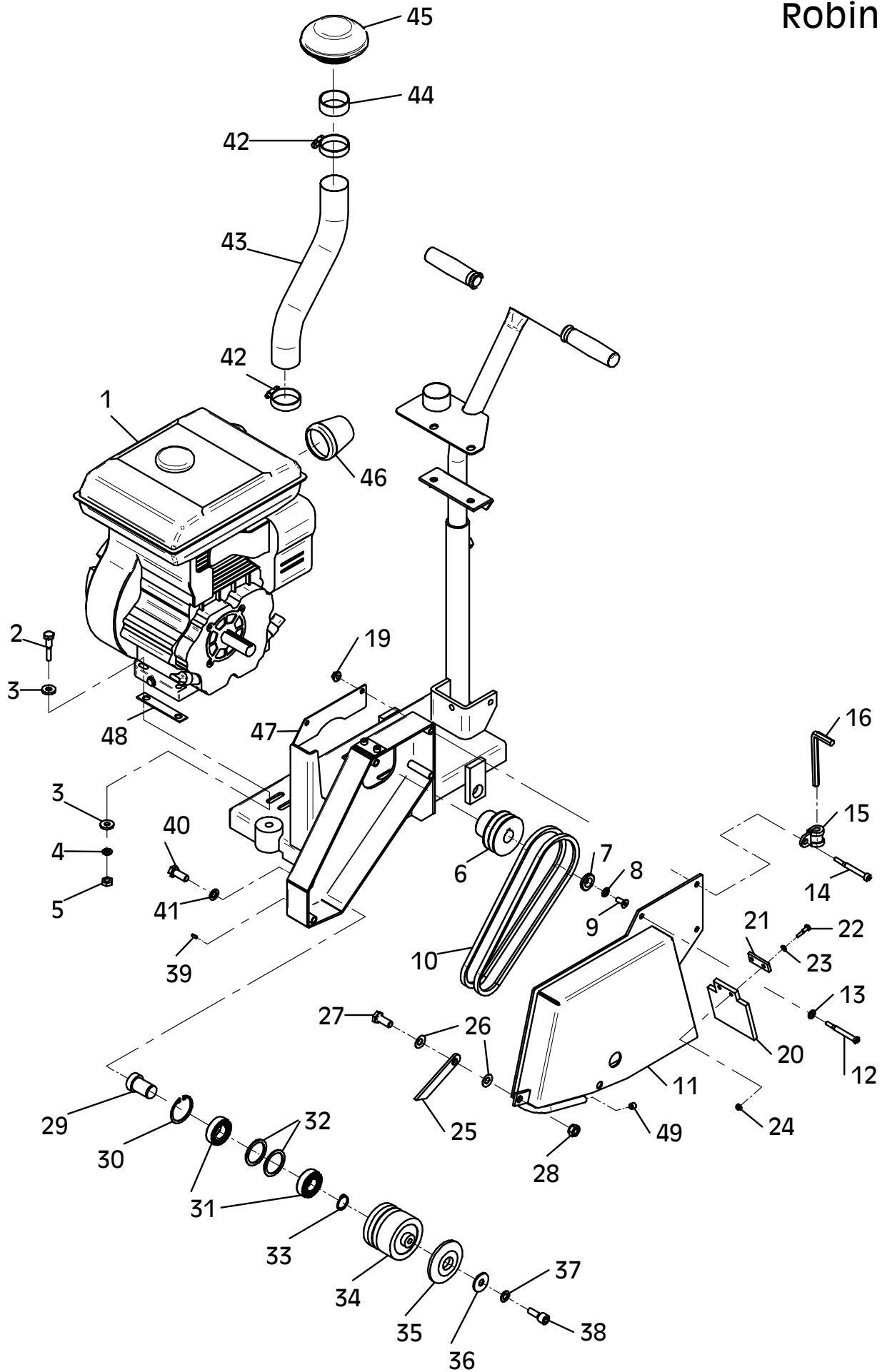

E 3044-0610

Position Ref.No. Repère Posizione	Menge Quantity Quantité Quantità Cantidad	Teile-Nr. Part-No. No. Référence Nr. d'Ordine No. Referenzia	Hinweis Hints Indications Indicazione Indicaciones	Position Ref. No. Repère Posizione	Menge Quantity Quantité Quantità Cantidad	Teile-Nr. Part-No. No. Référence Nr. d'Ordine No. Referenzia	Hinweis Hints Indications Indicazione Indicaciones
1	1	20001230		30	1	25035009	DIN472-I52x2
2	4	25040068	DIN931-M10x45	31	2	25001037	
3	8	25049020	DIN7349-10,5	32	2	25025176	DIN988-SS-42x52x2,5
4	4	20029001	VSK 10	33	1	25034016	DIN471-A25x1,2
5	4	25031004	DIN934-M10	34	1	10016719	
6	1	10016718		35	1	10008244	
7	1	10005346		36	1	25048012	DIN9021-13x40x3
8	1	25005003	DIN6798-V8,4	37	1	20029004	VSK 12
9	1	25047017	DIN7991-M8x20	38	1	25044075	DIN912-M12x30
10	2	25002021		39	1	25036021	
11	1	10022568		40	1	25038020	DIN933-M12x30
12	3	25044126	DIN912-M8x75	41	1	20029004	VSK 12
13	3	25048002	DIN125-A8,4	42	1	10016190	
14	1	25044060	DIN912-M8x80	43	1	20007035	
15	1	20007001		44	1	25048002	DIN125-A8,4
16	1	25025204		45	1	25040007	DIN931-M8x70
17				46	1	20026384	
18				47	4	20026389	
19	4	20022002	Tensilock M8	49	1	21000619	DIN913-M10x10
20	1	10007356		50	1	10016954	
21	1	10007006					
22	2	25038069	DIN933-M6x25				
23	2	25048001	DIN125-A6,4				
24	2	25031012	DIN985-M6				
25	1	10008027					
26	2	20008013					
27	1	25038020	DIN933-M12x30				
28	1	25031015	DIN985-M12				
29	1	10007354					

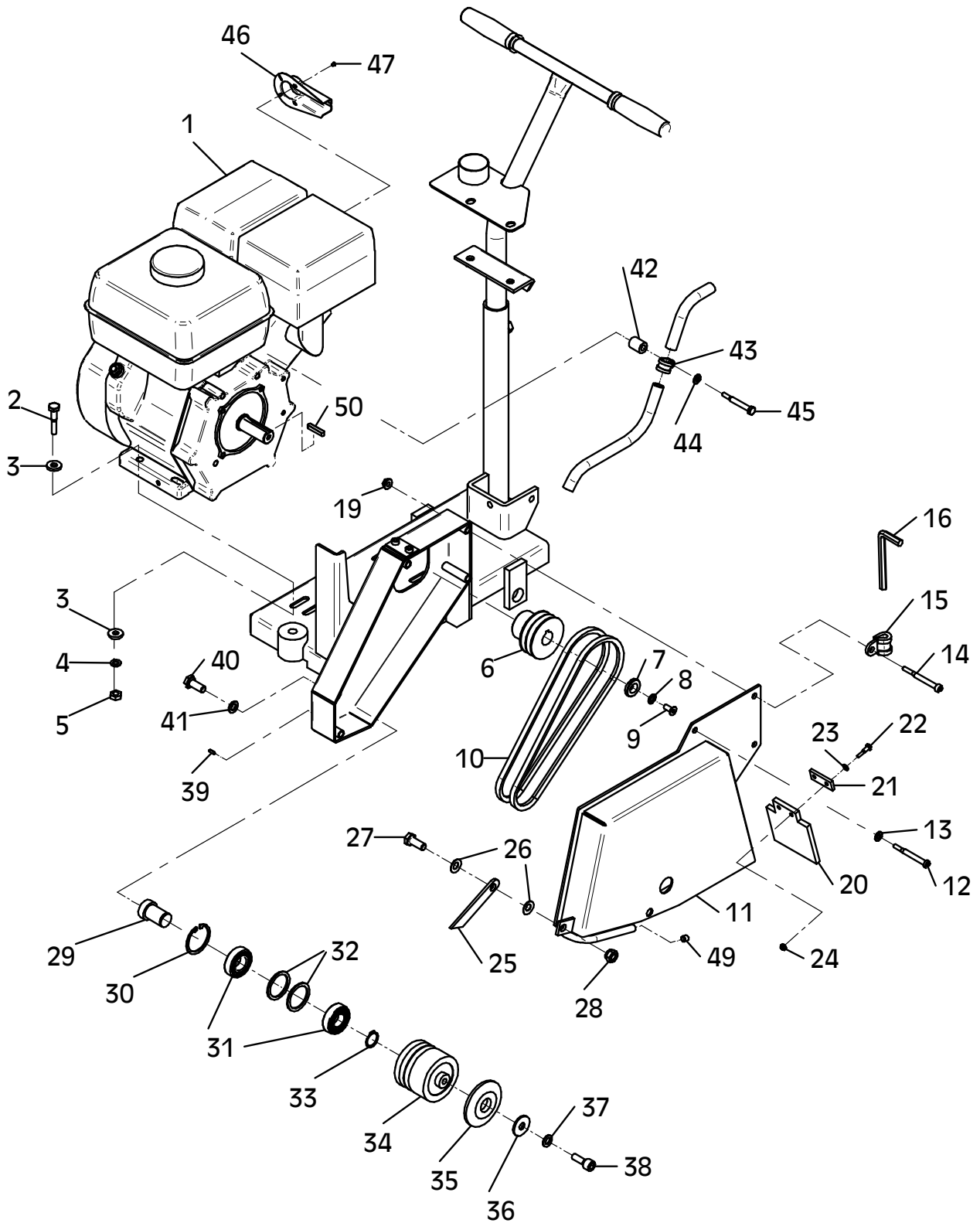

E 3670-1215

Position Ref.No. Repère Posizione Posicion	Menge Quantity Quantité Quantità Cantidad	Teile-Nr. Part-No. No. Référence Nr. d'Ordine No. Referenzia	Hinweis Hints Indications Indicazione Indicaciones	Position Ref. No. Repère Posizione Posicion	Menge Quantity Quantité Quantità Cantidad	Teile-Nr. Part-No. No. Référence Nr. d'Ordine No. Referenzia	Hinweis Hints Indications Indicazione Indicaciones
1	1	20001115		31	1	10007354	
2	1	10022047		32	1	25035009	DIN472-J52x2,0
3	4	25038008	DIN933-M8x25	33	2	25001037	
4	4	20029003	VSK 8	34	2	25025176	DIN988-SS-42x52x2,5
5	4	25048002	DIN125-A8,4	35	1	25034016	DIN471-A25x1,20
6	4	25038013	DIN933-M10x20	36	1	10016719	
7	4	20029001	VSK 10	37	1	10008244	
8	4	25048003	DIN125-A10,5	38	1	25044075	DIN912-M12x30
9	1	25009017		39	1	20029004	VSK 12
10	1	11000081		40	1	25048012	DIN9021-13x40x3
11	1	25049016	DIN440-R9	41	1	25038020	DIN933-M12x30
12	1	20029003	VSK 8	42	1	20029004	VSK 12
13	1	25038006	DIN933-M8x16	43	1	25036021	
14	2	25002022		44	1	30047339	
15	1	10022568		45	4	20022002	Tensilock M8
16	3	25044126	DIN912-M8x75	46	2	20007034	
17	3	25048002	DIN125-A8,4	47	1	10015639	
18	1	25044060	DIN912-M8x80	48	2	25040007	DIN931-M8x70
19	1	20007001		49	2	25048002	DIN125-A8,4
20	1	25025204		50	2	20022002	Tensilock M8
21	1	10007356		51	1	20012161	
22	1	10007006		52	4	25023015	DIN85-M4x16
23	2	25038069	DIN933-M6x25	53	4	25048020	DIN125-A4 Ms
24	2	25048001	DIN125-A6,4	54	4	20029005	VSK 4
25	2	25031012	DIN985-M6	55	4	25031008	DIN934-M4
26	1	10008027		56	1	25009032	
27	2	20008013					
28	1	25038020	DIN933-M12x30				
29	1	25031015	DIN985-M12				
30	1	21000619	DIN913-M10x10				

400 V

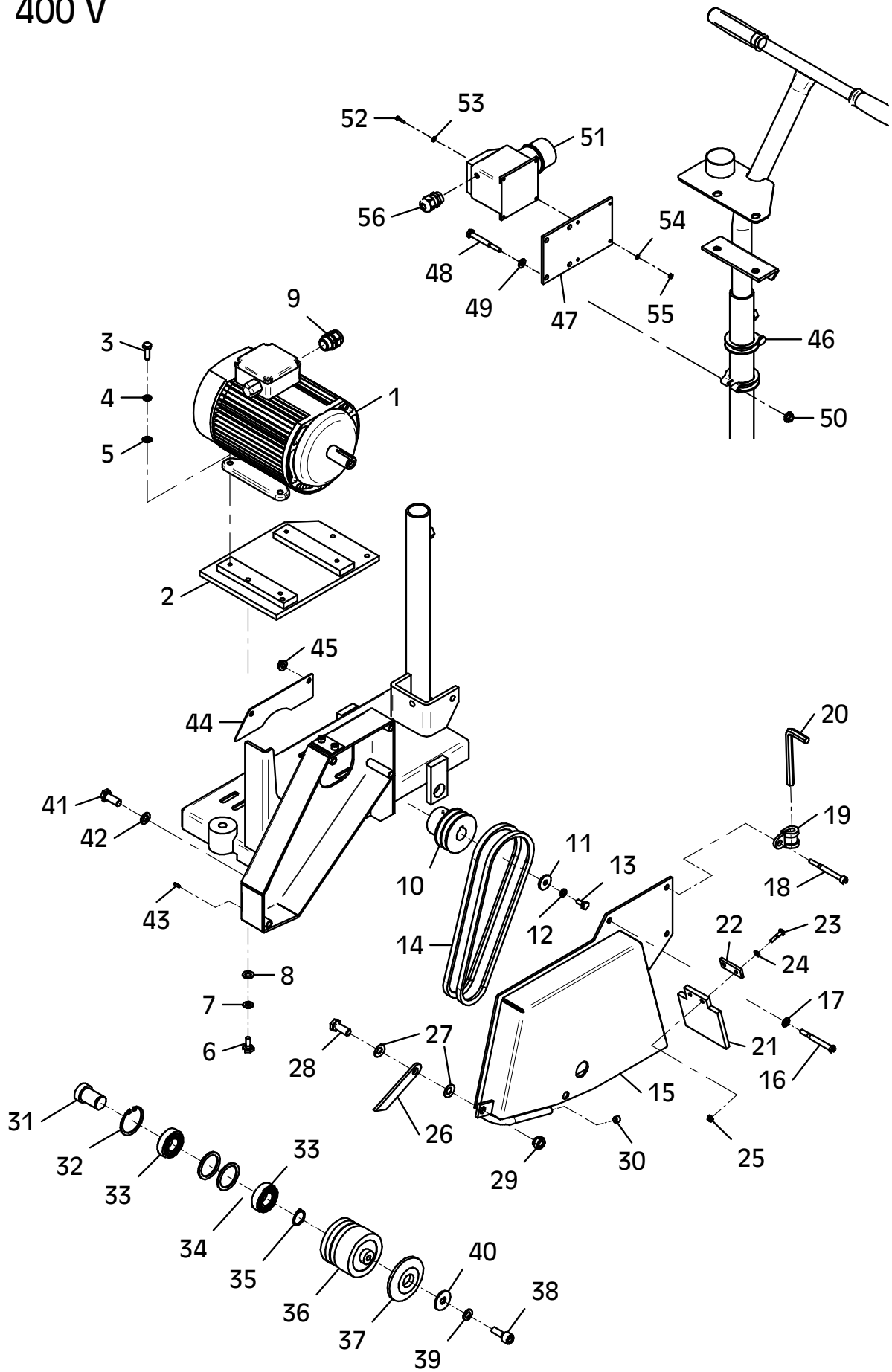

E 3670-1215

E 3045-0808

Position Ref.No. Repère Posizione Posicion	Menge Quantity Quantité Quantita Cantidad	Teile-Nr. Part-No. No. Référence Nr. d'Ordine No. Referenzia	Hinweis Hints Indications Indicazione Indicaciones	Position Ref. No. Repère Posizione Posicion	Menge Quantity Quantité Quantita Cantidad	Teile-Nr. Part-No. No. Référence Nr. d'Ordine No. Referenzia	Hinweis Hints Indications Indicazione Indicaciones
1	1	20025606					
2	2	25044022	DIN912-M10x140				
3	2	20029022	SKB 10				
4	1	20030016					
5	1	25048014	DIN1441-21x32x4				
6	1	20030018					
7	1	20030010					
8	1	10009676					
9	1	20007038					
10	1	20007072					
11	1	20007074					

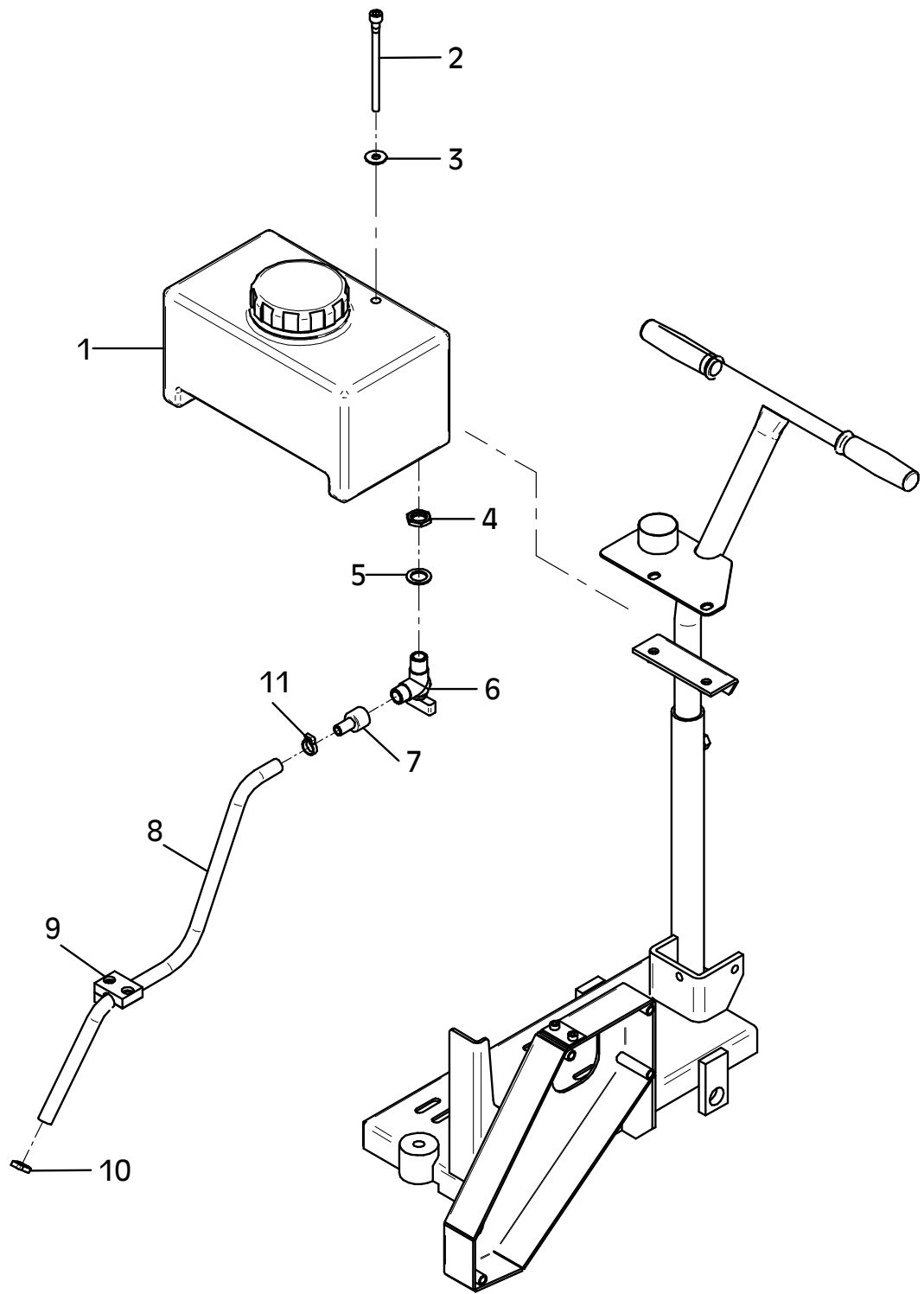

E 3045-0808

E 3046-0502

Position Ref.No. Repère Posizione Posicion	Menge Quantity Quantité Quantita Cantidad	Teile-Nr. Part-No. No. Référence Nr. d'Ordine No. Referenzia	Hinweis Hints Indications Indicazione Indicaciones	Position Ref. No. Repère Posizione Posicion	Menge Quantity Quantité Quantita Cantidad	Teile-Nr. Part-No. No. Référence Nr. d'Ordine No. Referenzia	Hinweis Hints Indications Indicazione Indicaciones
1	1	10003285					
2	1	25031003	DIN934-M8				
3	1	25038009	DIN933-M8x30				
4	1	10003286					
5	1	20029003	VSK 8				
6	1	25038009	DIN933-M8x30				
7	1	10003287					
8	1	25048002	DIN125-A8,4				
9	1	20029003	VSK 8				
10	1	25038007	DIN933-M8x20				
11	2	20025289					
12	4	25048002	DIN125-A8,4				
13	2	25040003	DIN931-M8x50				
14	2	25031003	DIN934-M8				

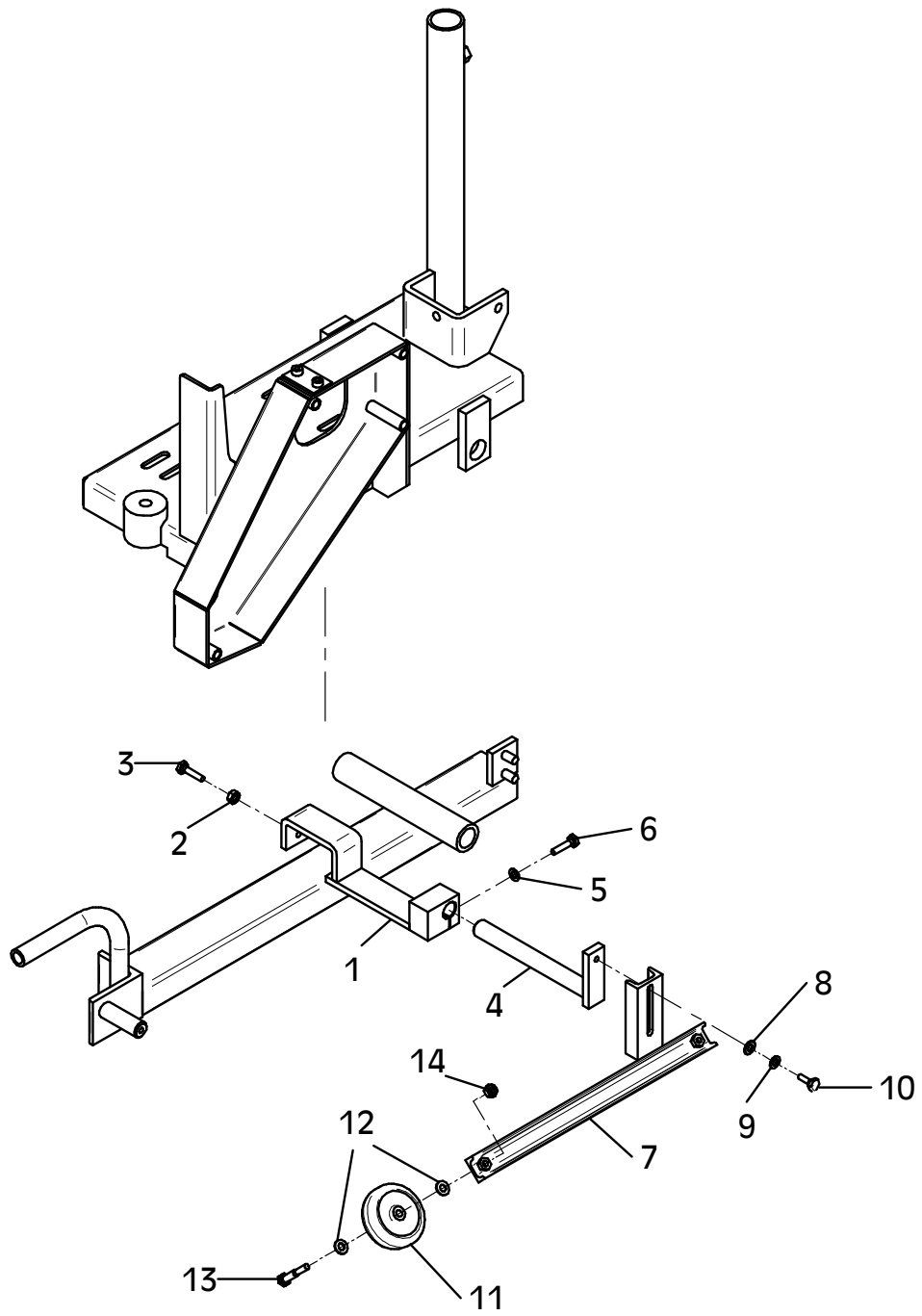

E 3046-0502

E 3576-0614

Position Ref.No. Repère Posizione Posicion	Menge Quantity Quantité Quantita Cantidad	Teile-Nr. Part-No. No. Référence Nr. d'Ordine No. Referenzia	Hinweis Hints Indications Indicazione Indicaciones	Position Ref. No. Repère Posizione Posicion	Menge Quantity Quantité Quantita Cantidad	Teile-Nr. Part-No. No. Référence Nr. d'Ordine No. Referenzia	Hinweis Hints Indications Indicazione Indicaciones
1	1	20019006					
2	1	21000701					
3	1	20019376					
4	1	20019007					
5	1	21000639					
6	1	21000474					
7	1	20019108					
8	1	20019097					
9	1	20019104					
10	1	20019076					
11	1	20019112					
12	1	21000638					
13	1	20019054					
14	1	20019100					
15	1	20019351					
16	1	21000621					
17	1	20019326					

Alle Schraubenverbindungen ständig auf festen Sitz überwachen!
 -Besonders nach dem ersten Einsatz-

Continuously check all screwed connections for firm seating
 -particularly after initial employment-

Controler continuellement tous les raccords a vis pour un siege ferme
 -particulierement apres l'emploi initial-

1

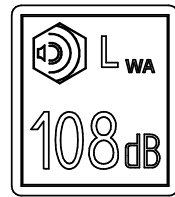

3

 **Achtung Erstickungsgefahr!**
 Maschine mit Verbrennungsmotor nicht in geschlossenen Räumen betreiben.

Caution! Danger of suffocation!
 Never operate the machine with combustion engine in enclosed areas.

Attention! Danger d'étouffement!
 Il ne faut jamais faire fonctionner la machine à moteur à combustion dans des locaux fermés.

2

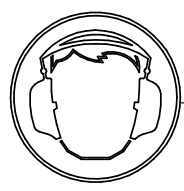

4



5

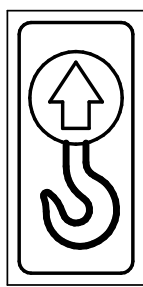

6

 **Vor Öffnen des Gehäuses Netzstecker ziehen!**

7

Normalbenzin
Gasoline
Essence

8

Wasser
Water
Eau

9

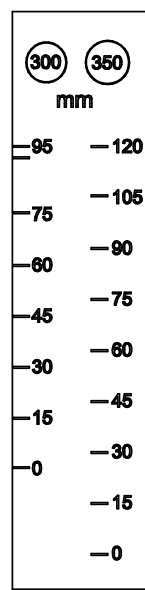

10

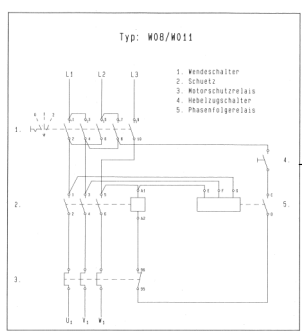

11

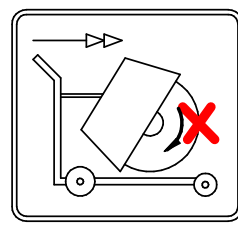

12

13

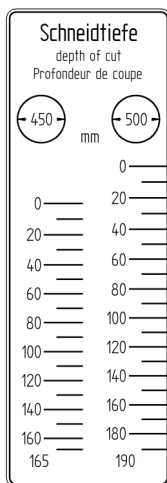
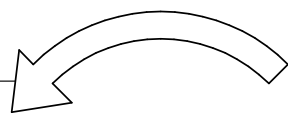

16

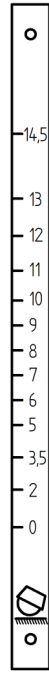

17

"Tiefeneinstellung nur bei stehendem Motor"

"Do not adjust cutting depth whilst engine is running"

"Reglage en profondeur uniquement moteur a l'arret"

14

Bei Keilriemenwechsel Innensechskantschraube nicht lösen!

Do not loosen the hexagon-socket head screw when changing u-belt!

La vis a six pans creux ne doit pas etre desserree lorsqu'on change la courroie trapezoidale!

15

Wenn Sie Fragen, Anregungen, Probleme, usw. haben, wenden Sie sich bitte an eine der unten genannten Adressen:

For problems, questions and further information refer to one of the following addresses:

Si des questions, des suggestions, des problèmes ... survenaient, veuillez vous adresser a l'une des adresses - ci dessous

<p>in Deutschland</p> <p>in Germany</p> <p>Pour l' Allemagne</p>	<p>WEBER Maschinentechnik GmbH Im Boden 5-8 , 10 57334 Bad Laasphe – Rückershausen</p>	<p>Telefon + 49 (0) 2754 - 398-0 Telefax + 49 (0) 2754 - 398101-Zentrale switchboard Central + 49 (0) 2754 - 398102-Ersatzteil-Direktlinie spare parts-directlinie Ligne direct pièces détachées</p> <p>E-Mail g.voelkel@webermt.de</p>
<p>in Frankreich</p> <p>in France</p> <p>Pour la France</p>	<p>WEBER Technologie SARL 26' rue d' Arsonval 69680 Chassieu</p>	<p>Telefon + 33 (0) 472 - 791020 Telefax + 33 (0) 472 - 791021</p> <p>E-Mail france@webermt.com</p>
<p>in Polen</p> <p>in Poland</p> <p>Pour la Pologne</p>	<p>WEBER Maschinentechnik Sp. zo.o. Ul. Grodziska 7 05-830 Stara Wies</p>	<p>Telefon + 48 (0) 22 - 739 70 - 80 + 48 (0) 22 - 739 70 - 81 Telefax + 48 (0) 22 - 739 70 - 82</p> <p>E-Mail info@webermt.com.pl</p>
<p>in Tschechien</p> <p>in Czechia</p> <p>Pour la Tchéquie</p>	<p>WEBER MT s.r.o. V Piskovně 2054 278 01 Kralupy nad Vitavou</p>	<p>Telefon + 42 (0) 776 222 216 + 42 (0) 776 222 261</p> <p>E-Mail info@webermt.cz</p>
<p>in USA und Kanada</p> <p>in USA and Canada</p> <p>Pour les Etats Unis Et le Canada</p>	<p>WEBER MT, Inc. 45 Dowd Road Bangor, ME 04401</p>	<p>Telefon + 1(207) - 947 - 4990 Telefax + 1(207) - 947 - 5452</p> <p>E-Mail sales@webermt.com service@webermt.com</p>
<p>in Süd – Amerika</p> <p>in South – America</p> <p>Pour l' Amérique du sud</p>	<p>WEBER Maschinentechnik do Brasil Rua João Werno Erhart, 4691 Bairro Rinção 93310 – 405 Novo Hamburgo / RS Brasilien</p>	<p>Telefon + 55 (0) 51- 587 3044 Telefax + 55 (0) 51- 587 2271</p> <p>E-Mail webermt@webermt.com.br</p>

