

Ersatzteile

Spare parts

Spare parts

Pièces de rechange

Piezas de recambio

Ricambi

Peças de reposição

Piese de schimb

Náhradných dielov

Reserveedele

Części zamienne



DVH 655-2

0140302 - 0140304

Ab Serien-Nr.



Weber Maschinenteknik GmbH

Im Boden 5 – 8 , 10

D- 57334 Bad Laasphe - Rückershausen / Germany

Tel.: +49 (0) 2754 / 398 0

Fax: +49 (0)2754 / 398 101

E-Mail: info@webermt.de

www.webermt.de

BITTE, NOTIEREN SIE SERIENNUMMER UND MOTORNUMMER IHRER MASCHINE:

PLEASE WRITE DOWN SERIALNUMBERS OF MACHINE AND ENGINE:

NOTEZ SVP LE NUMERO DE SERIE ET LE NUMERO DU MOTEUR DE VOTRE MACHINE:

SI PREGA DI ANNOTARE SEMPRE I NUMERI DI SERIE SIA DELLA VS. MACCHINA CHE DEL MOTORE:

MAQUINA: ROGAMOS ANOTEN EL NUMERO DE SERIE Y NUMERO DE MOTOR DE SU MAQUINA:

PROSIMY ZANOTOWAĆ NUMER MASZYNY I SILNIKA

MASCHINE
MACHINE
MACCHINA
MAQUINA
MASZYNA



MOTOR
ENGINE
MOTEUR
MOTORE
SILNIK



ZUR VERMEIDUNG VON FEHLLIEFERUNGEN UND VERZÖGERUNGEN SIND BEI DER BESTELLUNG VON ERSATZTEILEN FOLGENDE ANGABEN UNBEDINGT ERFORDERLICH:

- MASCHINENTYP
- SERIENNUMMER DER MASCHINE
- SERIENNUMMER DES MOTORS (BEI MOTORTEILEN)
- TEILENUMMER
- BESTELLMENGE

TO AVOID ERRORS IN DELIVERY PLEASE STATE THESE PARTICULARS WHEN ORDERING:

- TYPE OF MACHINE
- SERIAL NO. OF MACHINE
- SERIAL NO. OF ENGINE (ON ENGINE PARTS)
- PART-NO.
- QUANTITY REQUIRED

AFIN D'EVITER DES ERREURS DE COMMANDE ET DES RETARDS DE LIVRAISON IL EST NECESSAIRE D'INDIQUER LES CARACTERISTIQUES SUIVANTES:

- TYPE DE MACHINE
- LE NUMERO DE SERIE DE LA MACHINE
- LE NUMERO DE SERIE DU MOTEUR
- LE NUMERO D'IDENTITE DE LA PIECE
- LA QUANTITE SOUHAITEE

ONDE EVITARE DISGUIDI E RITARDI NELLE CONSEGNE DIE RICAMBI SI PREGA DI INDICARE SEMPRE:

- TIPO DELLA MACCHINA
- NUMERO DI SERIE DELLA MACCHINA
- NUMERO DI SERIE DEL MOTORE (SE SI RICHIEDONO PEZZI DEL MOTORE)
- NUMERO D'ORDINE DIE SINGOLI RICAMBI
- QUANTITA

A FI DE EVITAR ERRORES DE ENTREGA, ROGAMOS INDIQUEN LOS SIGUIENTES DATOS CUANDO PASE PEDIDOS DE RECAMBIO:

- MODELO DE MAQUINA
- NO. DE SERIE DE LA MAQUINA
- NO. DE SERIE DEL MOTOR (EN PIEZAS PARA MOTOR)
- REFERENCIA DEL RECAMBIO
- CANTIDAD PEDIDA

PROSIMY O PODANIE NASTĘPUJĄCYCH DANYCH PRZY SKŁADANIU ZAMÓWIENIA.

- TYP MASZYNY
- NUMER SERYJNY MASZYNY
- NUMER SERYJNY SILNIKA (PRZY CZĘŚCIACH DO SILNIKA)
- NUMER CZĘŚCI ZAMIEWNNEJ
- ZAMAWIANA ILOŚĆ

E 3141-0411

Position Ref.No. Repère Posizione Posicion	Menge Quantity Quantité Quantita Cantidad	Teile-Nr. Part-No. No. Référence Nr. d'Ordine No. Referenzia	Hinweis Hints Indications Indicazione Indicaciones	Position Ref. No. Repère Posizione Posicion	Menge Quantity Quantité Quantita Cantidad	Teile-Nr. Part-No. No. Référence Nr. d'Ordine No. Referenzia	Hinweis Hints Indications Indicazione Indicaciones
1	1	10022112					
2	1	10022113					
3	2	10015822					
4	2	30043933					
5	4	25044030	DIN912-M16x70				
6	4	20029029					
7	2	10022116					
8	4	25038016	DIN933-M10x35				
9	4	20029001	VSK 10				
10	2	10009667					
11	2	25015029					
12	2	25028021	DIN916-M10x20				

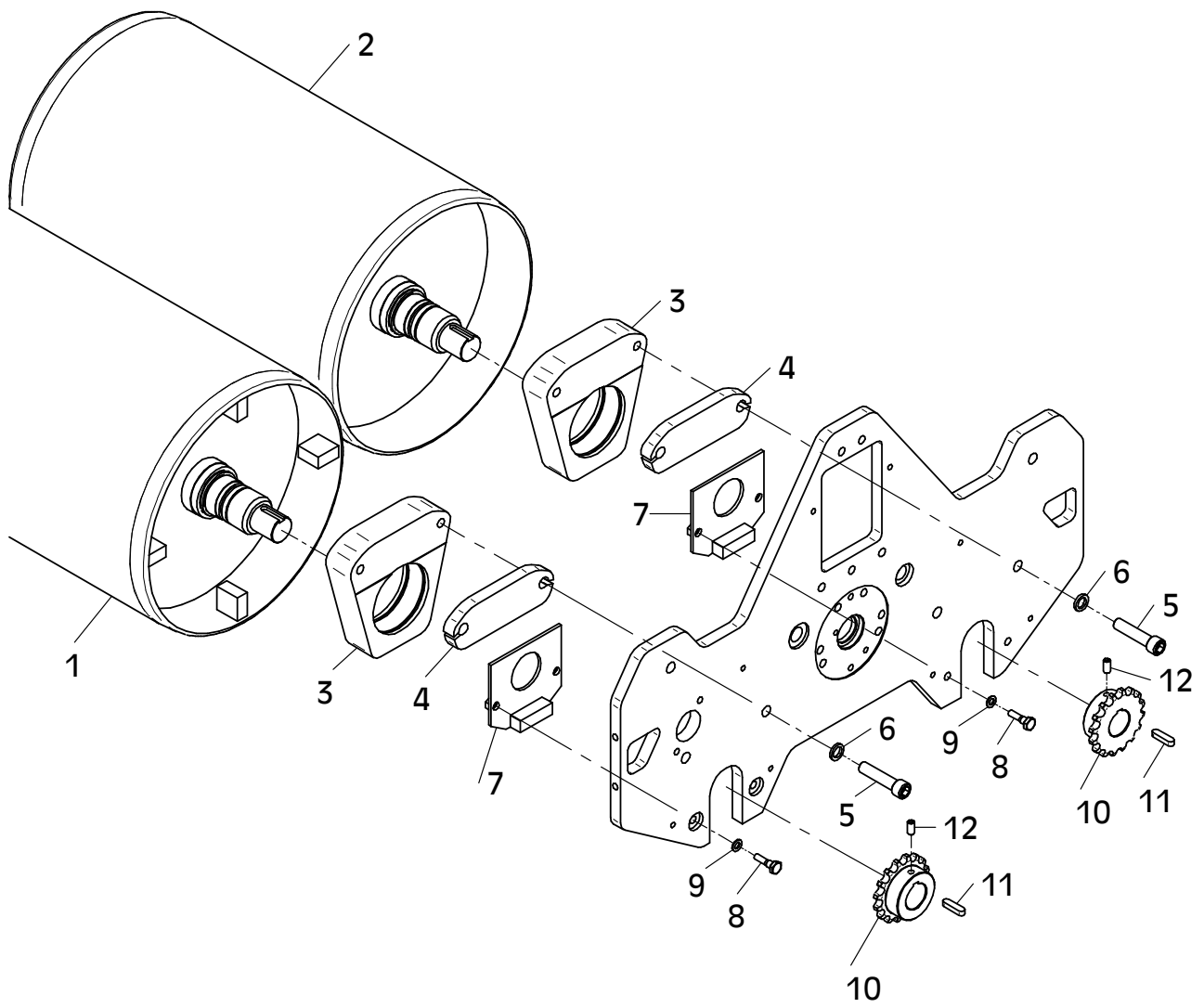

E 3141-0411

E 3441-0411

Position Ref.No. Repère Posizione Posicion	Menge Quantity Quantité Quantita Cantidad	Teile-Nr. Part-No. No. Référence Nr. d'Ordine No. Referenzia	Hinweis Hints Indications Indicazione Indicaciones	Position Ref. No. Repère Posizione Posicion	Menge Quantity Quantité Quantita Cantidad	Teile-Nr. Part-No. No. Référence Nr. d'Ordine No. Referenzia	Hinweis Hints Indications Indicazione Indicaciones
1	2	10015823					
2	2	10022117					
3	4	25040066	DIN931-M16x55				
4	4	20029029					

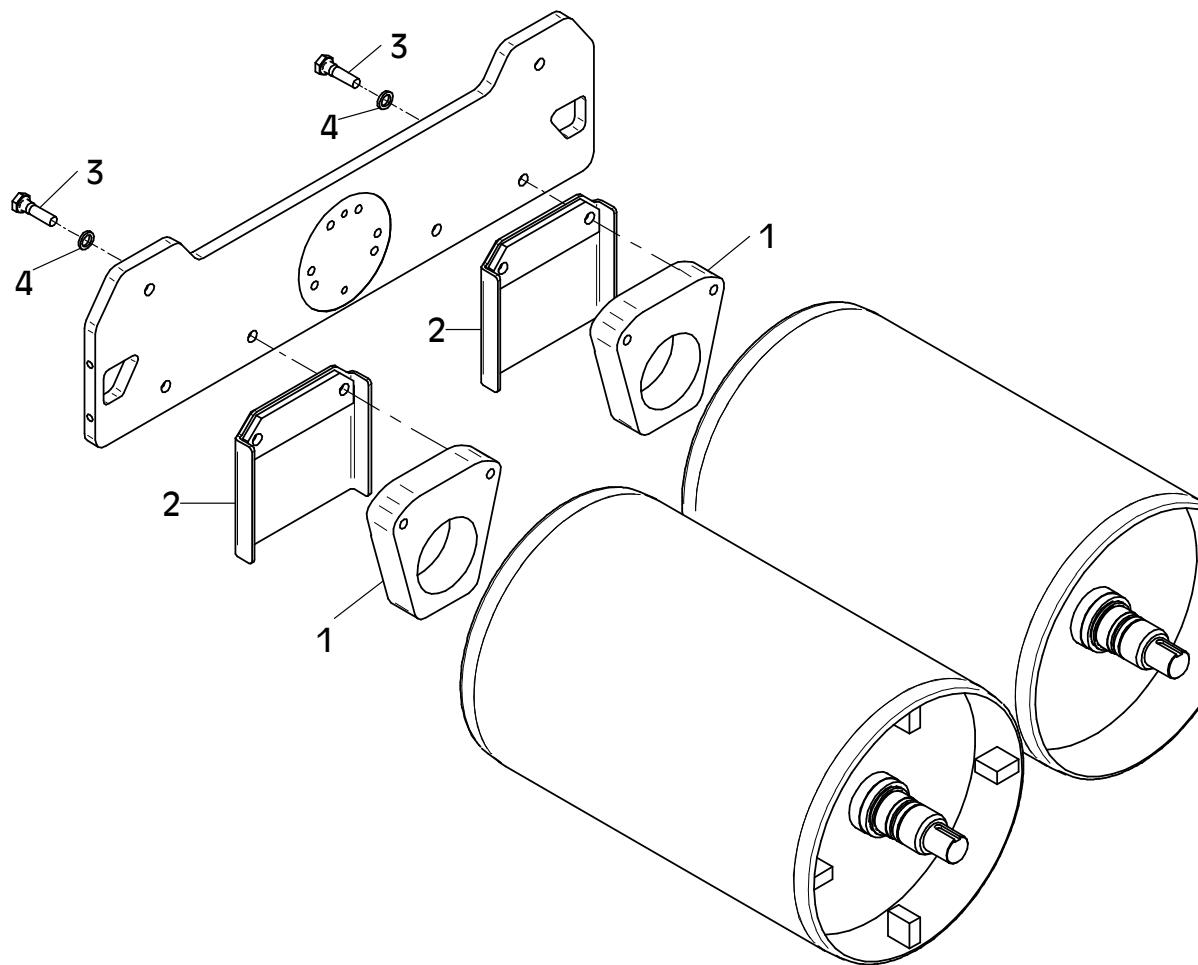

E 3441-0411

E 3442-0411

Position Ref.No. Repère Posizione Posicion	Menge Quantity Quantité Quantità Cantidad	Teile-Nr. Part-No. No. Référence Nr. d'Ordine No. Referenzia	Hinweis Hints Indications Indicazione Indicaciones	Position Ref. No. Repère Posizione Posicion	Menge Quantity Quantité Quantità Cantidad	Teile-Nr. Part-No. No. Référence Nr. d'Ordine No. Referenzia	Hinweis Hints Indications Indicazione Indicaciones
1	4	20013259					
2	4	25035024	DIN472-I1110x4				
3	4	20013260					
4	4	25025232	DIN988-SS- 85x105x3,5				
5	4	25001505					
6	4	20013261					
7	2	10015816					
8	4	25034026	DIN471-A58x2				
9	2	20025115					
10	2	10015819					
11	4	20013084					
12	2	10015817					

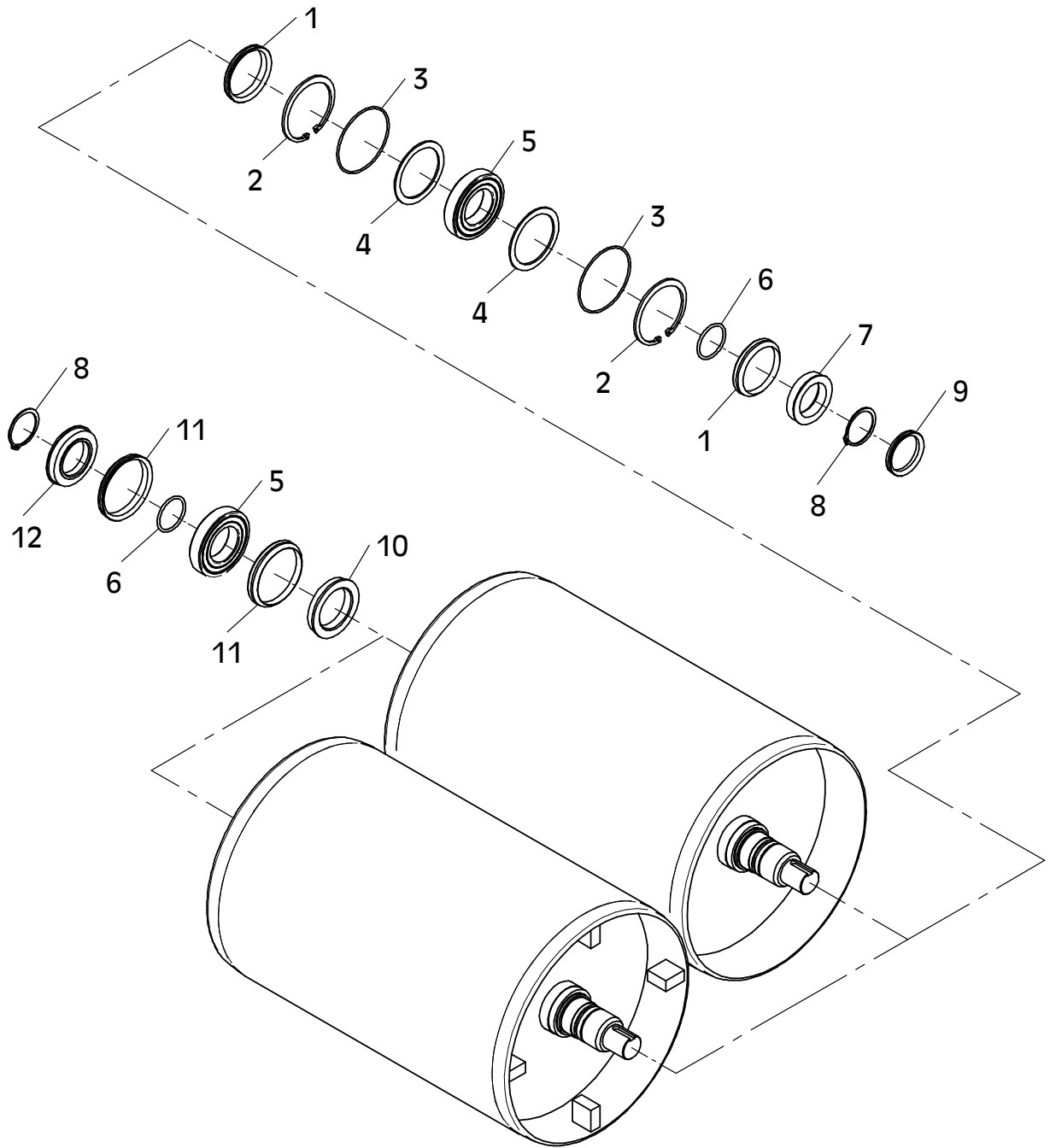

E 3442-0411

E 3142-0411

Position Ref.No. Repère Posizione Posicion	Menge Quantity Quantité Quantita Cantidad	Teile-Nr. Part-No. No. Référence Nr. d'Ordine No. Referenzia	Hinweis Hints Indications Indicazione Indicaciones	Position Ref. No. Repère Posizione Posicion	Menge Quantity Quantité Quantita Cantidad	Teile-Nr. Part-No. No. Référence Nr. d'Ordine No. Referenzia	Hinweis Hints Indications Indicazione Indicaciones
1	2	30043926					
2	3	25038022	DIN933-M12x40				
3	3	20029023	SKB 12				
4	2	30043927					
5	6	25038015	DIN933-M10x30				
6	6	20029022	SKB 10				
7	1	10022109					
8	1	10022110					
9	10	25038019	DIN933-M12x25				
10	10	20029004	VSK 12				
11	2	25048004	DIN125-A13				
12	1	10015809					
13	1	10015810					
14	1	10022111					
15	2	25044075	DIN912-M12x30				
16	2	20029004	VSK 12				
17	1	10008063					
18	1	20025762					
19	1	20008051					
20	1	20025763					
21	5	25044027	DIN912-M12x45				
22	5	20025158					
23	1	10001395					
24	1	10015813					
25	1	10015814					

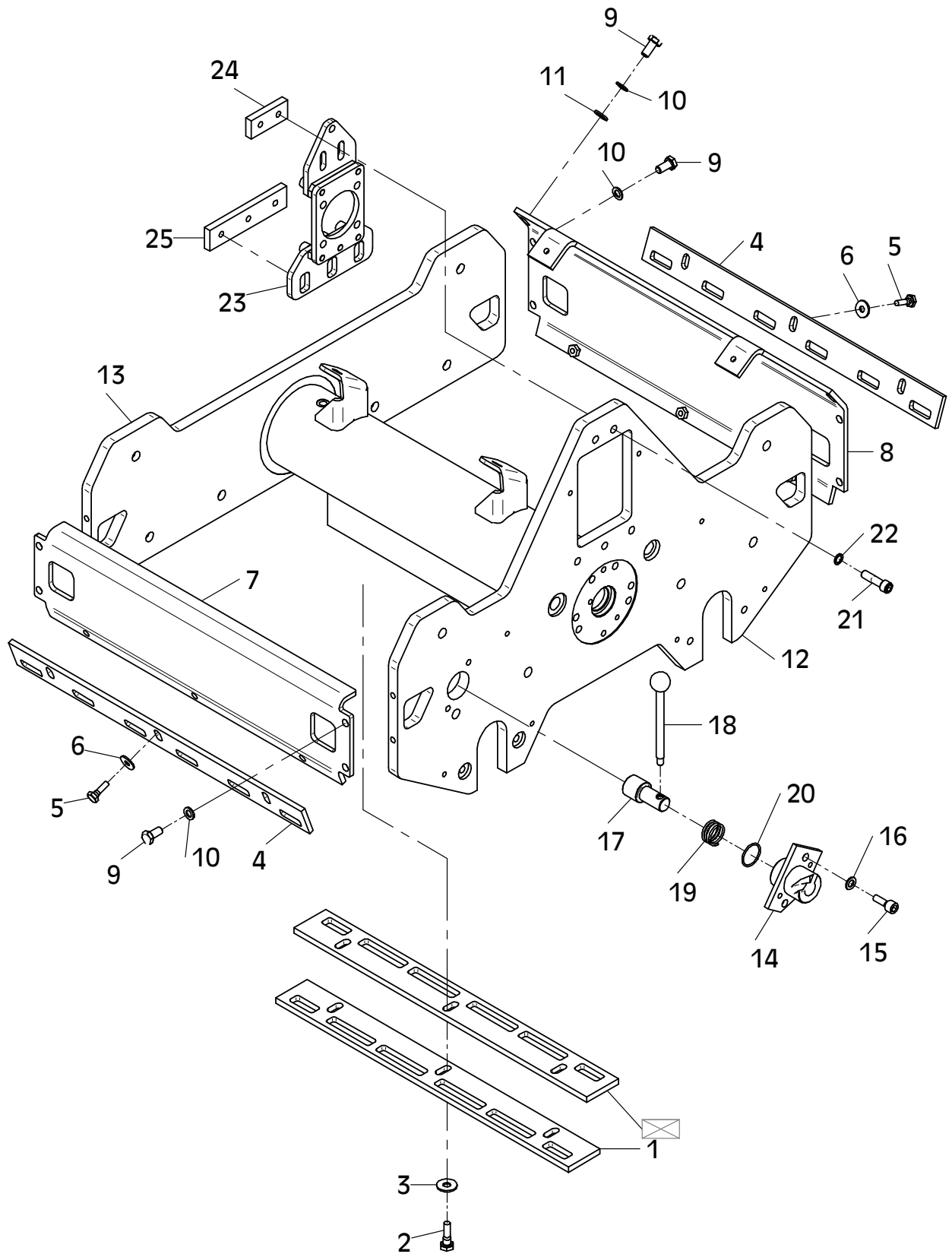

E 3142-0411

E 3143-0411

Position Ref.No. Repère Posizione Posición	Menge Quantity Quantité Quantita Cantidad	Teile-Nr. Part-No. No. Référence Nr. d'Ordine No. Referenzia	Hinweis Hints Indications Indicazione Indicaciones	Position Ref. No. Repère Posizione Posición	Menge Quantity Quantité Quantita Cantidad	Teile-Nr. Part-No. No. Référence Nr. d'Ordine No. Referenzia	Hinweis Hints Indications Indicazione Indicaciones
1	1	11000318		31	1	11000571	
2	4	21000540		32	2	25038073	DIN933-M8x12
3	2	25038024	DIN933-M16x30	33	2	25048002	DIN125-A8,4
4	2	25038025	DIN933-M16x40	34	2	20022002	Tensilock M8
5	4	20029002	VSK 16				
6	8	25038008	DIN933-M8x25				
7	8	20029003	VSK 8				
8	1	10022121					
9	1	25038073	DIN933-M8x12				
10	1	20029021	SKB 8				
11	1	25038008	DIN933-M8x25				
12	1	20029021	SKB 8				
13							
14							
15							
16							
17							
18	1	25025034					
19	1	20008010					
20	1	25029005					
21	2	10008147					
22	2	20025582					
23	2	10008227					
24	2	20029009	VSK 20				
25	2	25040076	DIN931-M20x55				
26	2	25038083	DIN933-M16x60				
27	2	25031006	DIN934-M16				
28	1	11000569					
29	1	25038013	DIN933-M10x20				
30	1	20029022	SKB 10				

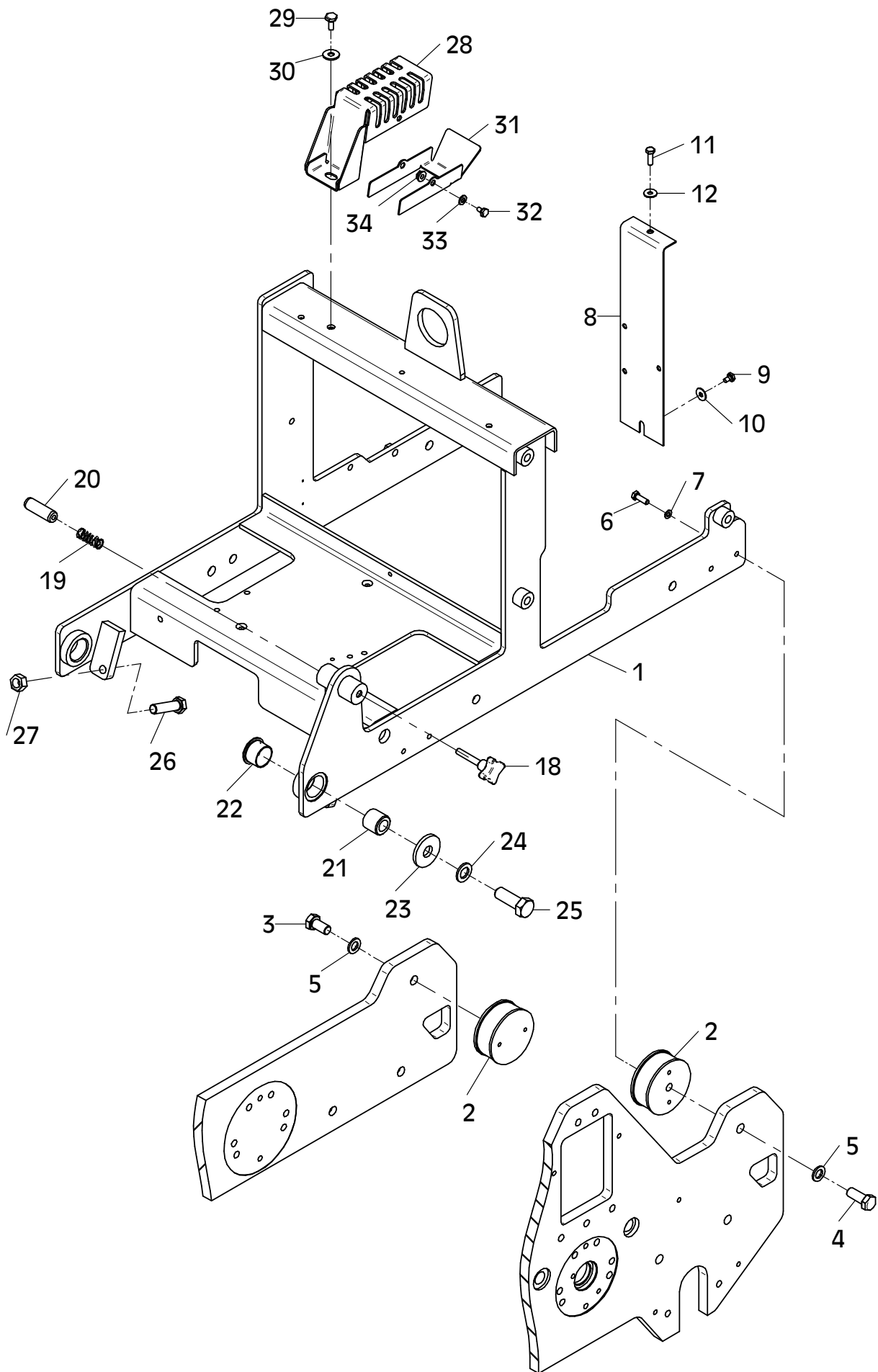

E 3143-0411

E 3144-0411

Position Ref.No. Repère Posizione Posición	Menge Quantity Quantité Cantidad	Teile-Nr. Part-No. No. Référence Nr. d'Ordine No. Referenzia	Hinweis Hints Indications Indicazione Indicaciones	Position Ref. No. Repère Posizione Posición	Menge Quantity Quantité Cantidad	Teile-Nr. Part-No. No. Référence Nr. d'Ordine No. Referenzia	Hinweis Hints Indications Indicazione Indicaciones
1	1	11000322		31	1	20018131	
2	1	10022611		32	1	25038014	DIN933-M10x25
3	5	25038006	DIN933-M8x16	33	1	20029001	VSK 10
4	5	25048002	DIN125-A8,4				
5	1	10022612					
6	4	25038006	DIN933-M8x16				
7	4	25048002	DIN125-A8,4				
8	1	10017008					
9	1	20033004					
10	1	25025837					
11	1	20008093					
12	2	20033005					
13	1	10022545					
14	1	20008092					
15	1	20026560					
16	1	10017007					
17	1	20018020					
18	2	25038070	DIN933-M6x30				
19	2	20029007	VSK 6				
20	1	20018021					
21	1	20006408					
22	1	20007007					
23	1	25038003	DIN933-M6x20				
24	1	25048001	DIN125-A6,4				
25	1	20022001	Tensilock M6				
26	1	10016358					
27	1	10017004					
28	2	25038003	DIN933-M6x20				
29	2	20029020	SKB 6				
30	2	20022001	Tensilock M6				

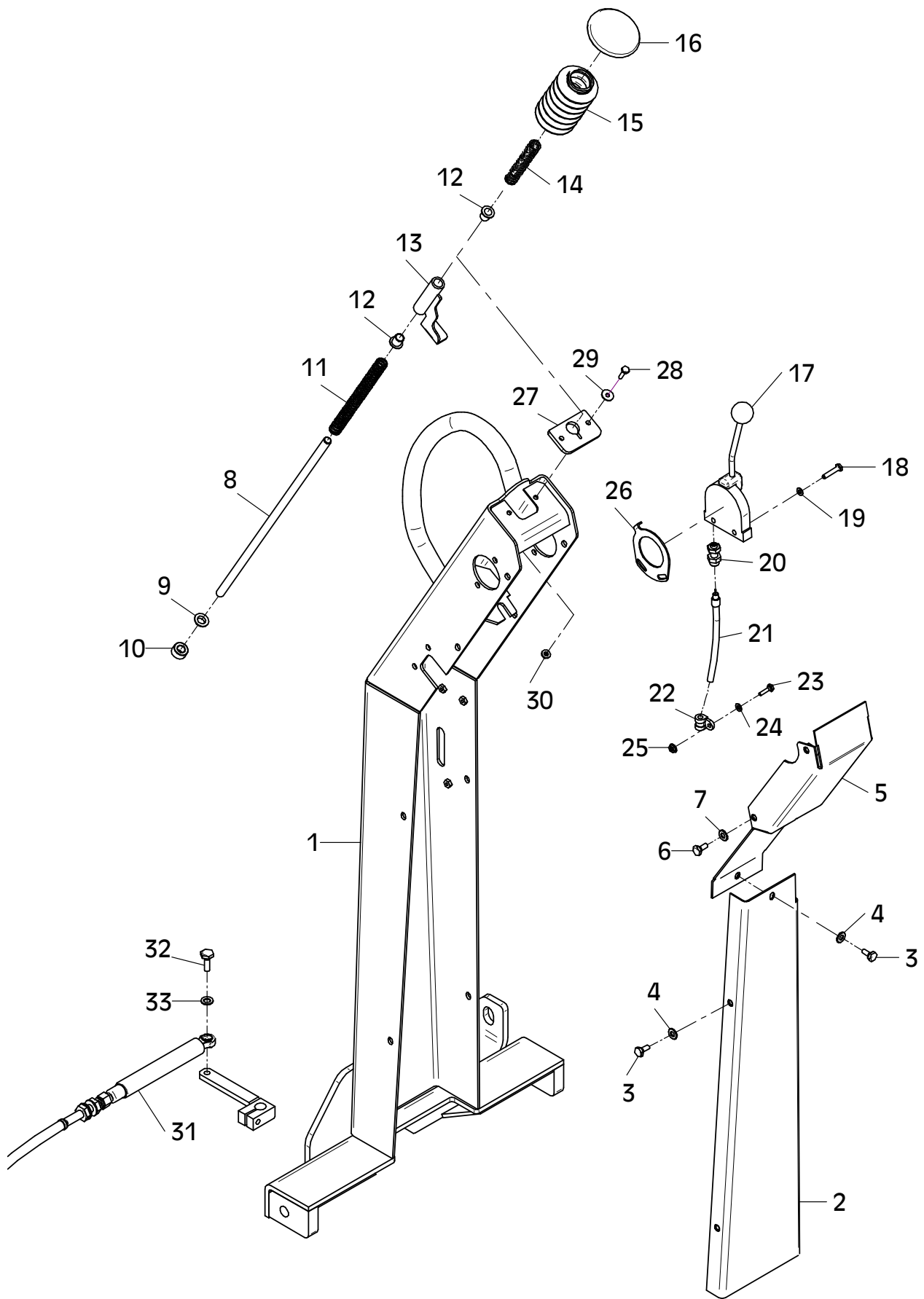

E 3144-0411

E 3443-0411

Position Ref.No. Repère Posizione Posición	Menge Quantity Quantité Cantidad	Teile-Nr. Part-No. No. Référence Nr. d'Ordine No. Referenzia	Hinweis Hints Indications Indicazione Indicaciones	Position Ref. No. Repère Posizione Posición	Menge Quantity Quantité Cantidad	Teile-Nr. Part-No. No. Référence Nr. d'Ordine No. Referenzia	Hinweis Hints Indications Indicazione Indicaciones
1	1	10022627					
2	1	10022626					
3	1	20026562					
4	1	25040058	DIN931-M8x130				
5	2	20029021	SKB 8				
6	1	25031046	DIN1587-M8				
8	2	25001307					
9	4	10016991					
10	4	25038007	DIN933-M8x20				
11	4	20025122					
12	2	25038020	DIN933-M12x30				
13	2	20029023	SKB 12				
14	1	10016439					
15	1	10016432					
16	1	25040065	DIN931-M8x40				
17	2	20029003	VSK 8				
18	1	25031003	DIN934-M8				
20	1	10001450					
21	1	10017015					
22	1	25029007					
23	1	20008094					
24	2	21000003					
25	1	10016428					
26	1	25025838					
27	1	25038010	DIN933-M8x35				
28	2	25049026	DIN7349-8,4				
29	1	25031013	DIN985-M8				

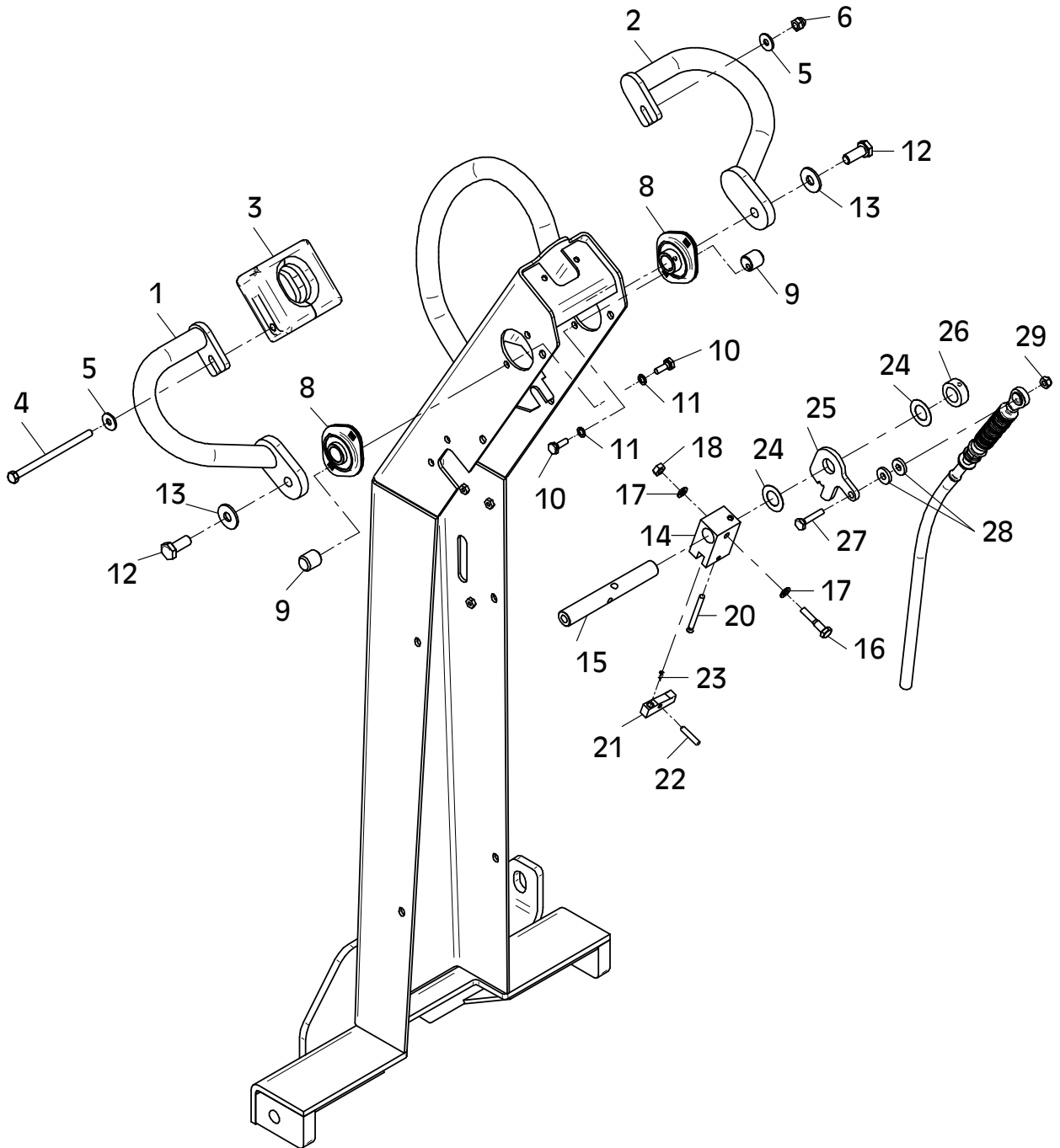

E 3443-0411

E 3145-0504

Position Ref.No. Repère Posizione Posicion	Menge Quantity Quantité Quantità Cantidad	Teile-Nr. Part-No. No. Référence Nr. d'Ordine No. Referenzia	Hinweis Hints Indications Indicazione Indicaciones	Position Ref. No. Repère Posizione Posicion	Menge Quantity Quantité Quantità Cantidad	Teile-Nr. Part-No. No. Référence Nr. d'Ordine No. Referenzia	Hinweis Hints Indications Indicazione Indicaciones
1	1	10022103					
2	2	25038022	DIN933-M12x40				
3	1	25040018	DIN931-M12x50				
4	3	20029004	VSK 12				
5	1	20022004	Tensilock M12				
6	1	20025764					
7	1	20020108					
8	1	21000518					
9	1	21000334					
10	1	25008017	DIN7603-22x27x1,5				
11	1	25031032	DIN934-M22x1,5				
12	1	10015802					
13	1	10022128					
14	6	25008003	DIN7603-8x14x1				
15	6	25038007	DIN933-M8x20				
16	1	20025365					
17	1	20025195					
18	1	10016994					
19	5	20022017	Tensilock M6x16				
20	5	25049004	DIN440-R6,6				
21	1	20026363					

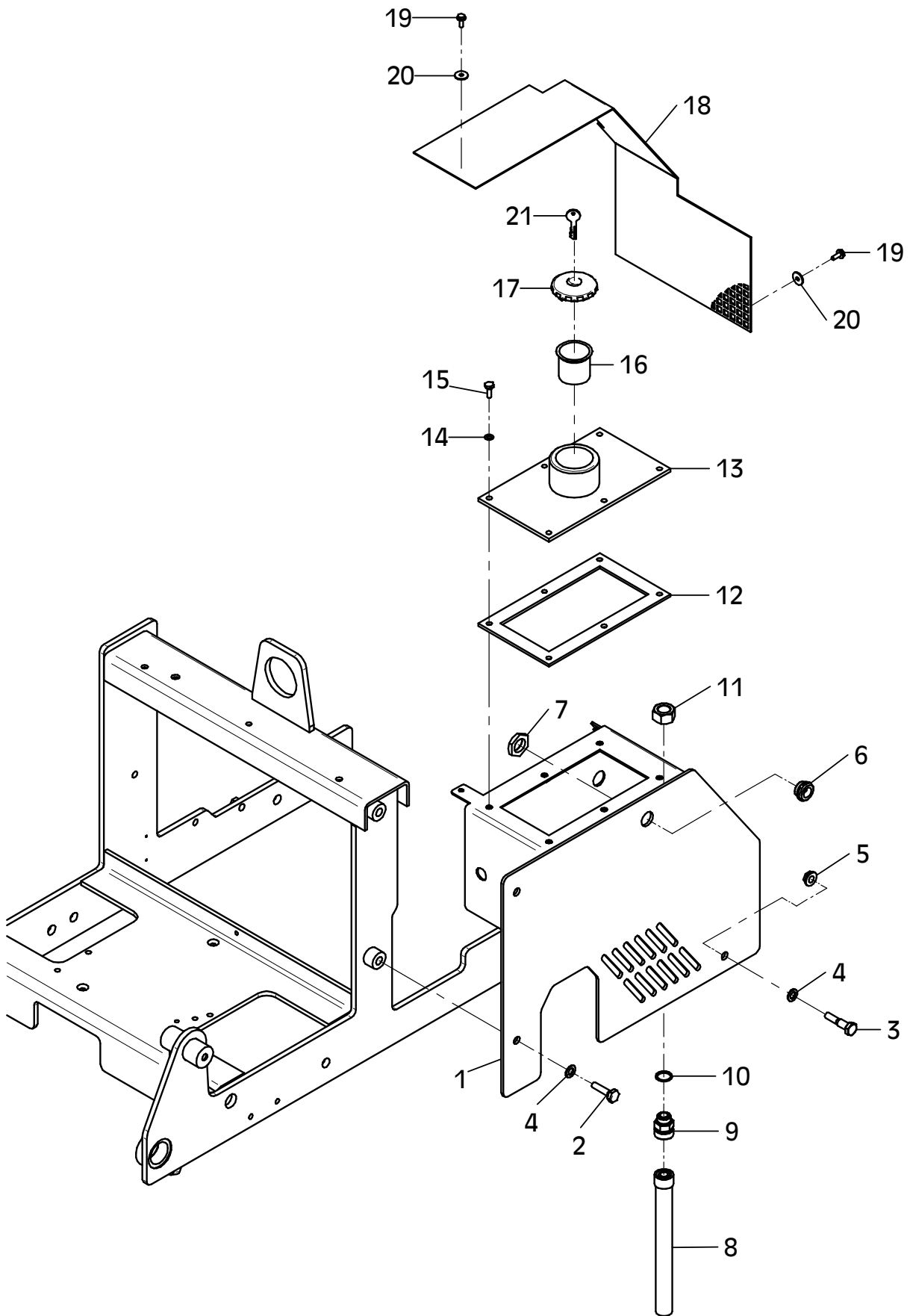

E 3145-0504

E 3146-0411

Position Ref.No. Repère Posizione Posicion	Menge Quantity Quantité Quantità Cantidad	Teile-Nr. Part-No. No. Référence Nr. d'Ordine No. Referenzia	Hinweis Hints Indications Indicazione Indicaciones	Position Ref. No. Repère Posizione Posicion	Menge Quantity Quantité Quantità Cantidad	Teile-Nr. Part-No. No. Référence Nr. d'Ordine No. Referenzia	Hinweis Hints Indications Indicazione Indicaciones
1	1	10022124		31	1	25048017	DIN125-A5,3
2	1	21000397		32	1	25049004	DIN440-R6,6
3	4	25048003	DIN125-A10,5	33	1	25027013	DIN913-M8x16
4	4	20029001	VSK 10	34	1	10022122	
5	4	25031004	DIN934-M10	35	2	25040030	DIN931-M10x40
6	1	10022608		36	2	20029001	VSK 10
7	1	25038006	DIN933-M8x16	37	1	10022129	
8	2	20029021	SKB 8	38	1	10022202	
9	1	20026556		39	2	20022018	Tensilock M8x20
10	2	25042006	3/8"-16UNC				
11	2	20029001	VSK 10				
12	1	40080306					
13	1	20007086					
14	1	40080291					
15	1	40080698					
16	1	21000518					
17	1	20026210					
18	1	25008016	DIN7603-14x18x1,5				
19	1	40080297					
20	1	40080296					
21	1	20025060					
22	1	25031002	DIN934-M6				
23	1	11001135					
24	1	11001134					
25	1	25038016	DIN933-M10x35				
26	1	20029001	VSK 10				
27	1	25007005					
28	1	10015846					
29	1	25044001	DIN912-M5x20				
30	1	20029006	VSK 5				

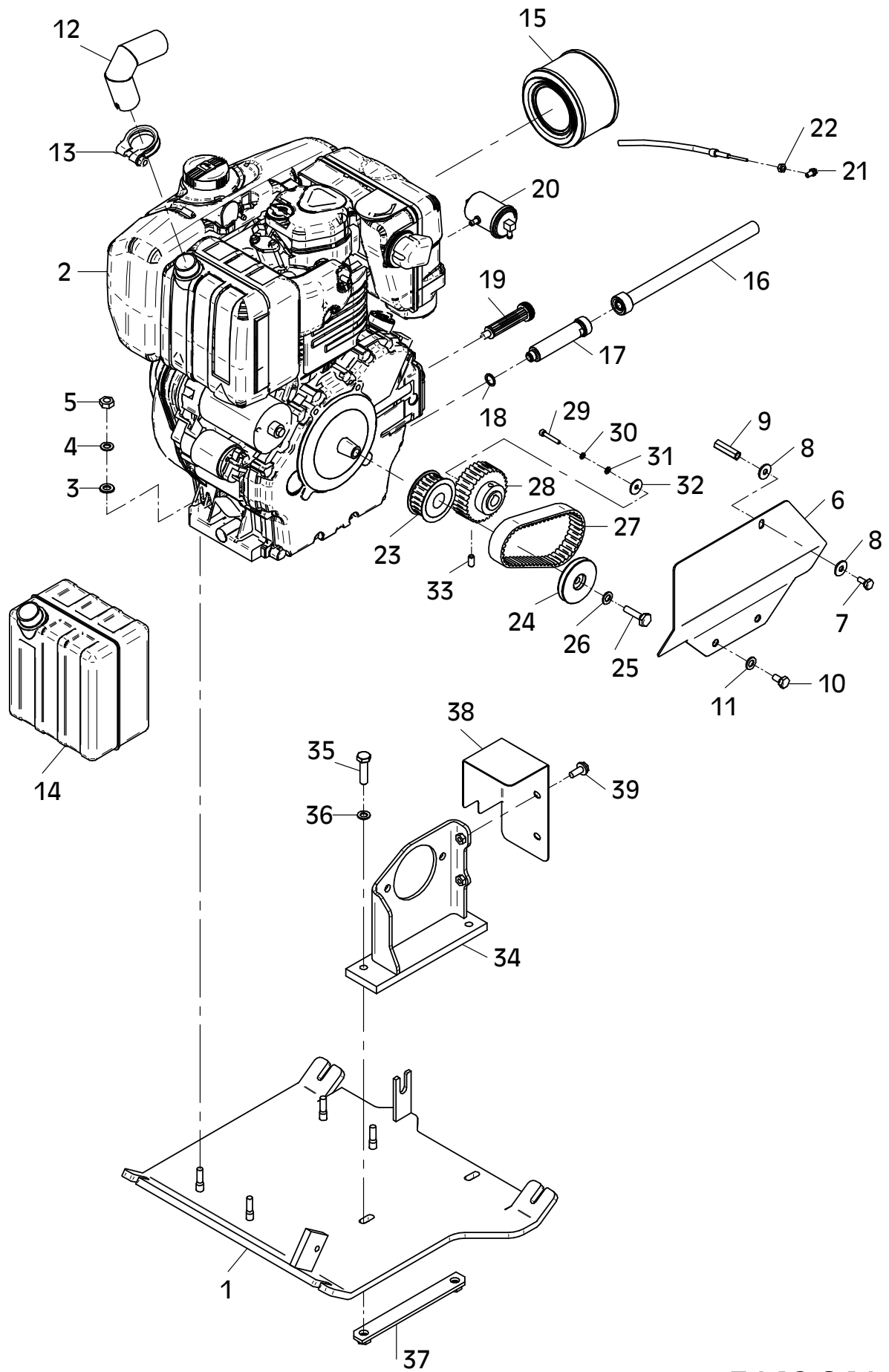

E 3146-0411

E 3444-0411

Position Ref.No. Repère Posizione Posicion	Menge Quantity Quantité Quantita Cantidad	Teile-Nr. Part-No. No. Référence Nr. d'Ordine No. Referenzia	Hinweis Hints Indications Indicazione Indicaciones	Position Ref. No. Repère Posizione Posicion	Menge Quantity Quantité Quantita Cantidad	Teile-Nr. Part-No. No. Référence Nr. d'Ordine No. Referenzia	Hinweis Hints Indications Indicazione Indicaciones
1	4	20004030					
2	4	25038007	DIN933-M8x20				
3	4	20029003	VSK 8				
4	4	25049016	DIN440-R9				
5	4	25038006	DIN933-M8x16				
6	4	20029003	VSK 8				
7	2	25048002	DIN125-A8,4				
8	1	10022126					
9	1	25038014	DIN933-M10x25				
10	1	20029001	VSK 10				
11	1	10015967					
12	2	25040001	DIN931-M6x60				
13	2	20022001	Tensilock M6				
14	1	10015965					
15	2	25048003	DIN125-A10,5				
16	2	25035021	DIN472-I30				
17	2	25025242	DIN988-SS-22x30x2				
18	1	25001208					
19	1	20025287					
20	1	25031004	DIN934-M10				
21	1	11001133					
22	1	25002034					
23	1	20026407					
24	1	25049004	DIN440-R6,6				
25	1	20025121					
26	1	25038005	DIN933-M6x40				

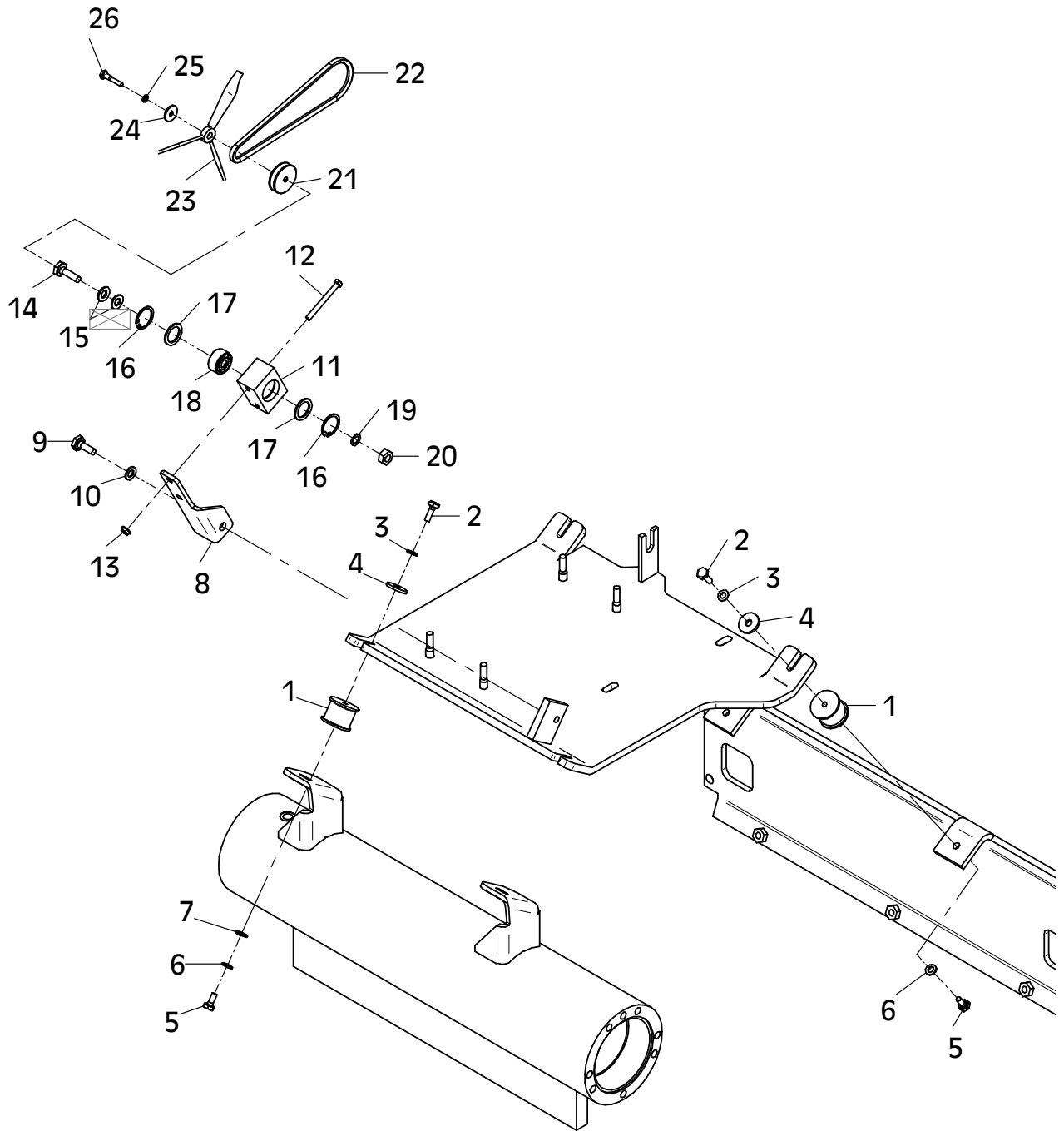

E 3444-0411

E 3147-0410

Position Ref.No. Repère Posizione Posicion	Menge Quantity Quantité Quantita Cantidad	Teile-Nr. Part-No. No. Référence Nr. d'Ordine No. Referenzia	Hinweis Hints Indications Indicazione Indicaciones	Position Ref. No. Repère Posizione Posicion	Menge Quantity Quantité Quantita Cantidad	Teile-Nr. Part-No. No. Référence Nr. d'Ordine No. Referenzia	Hinweis Hints Indications Indicazione Indicaciones
1	1	11000984					
1	1	11001003	ohne / without Logo				
2	8	21000588	DIN7964-M10x75				
3	8	20029001	VSK 10				
4	1	10016223					
5	2	10016232					
6	2	25024018					
7	1	25040027	DIN931-M8x35				
8	1	20026475					
9	1	10022130					
10	1	25044013	DIN912-M10x30				
11	1	20029001	VSK 10				

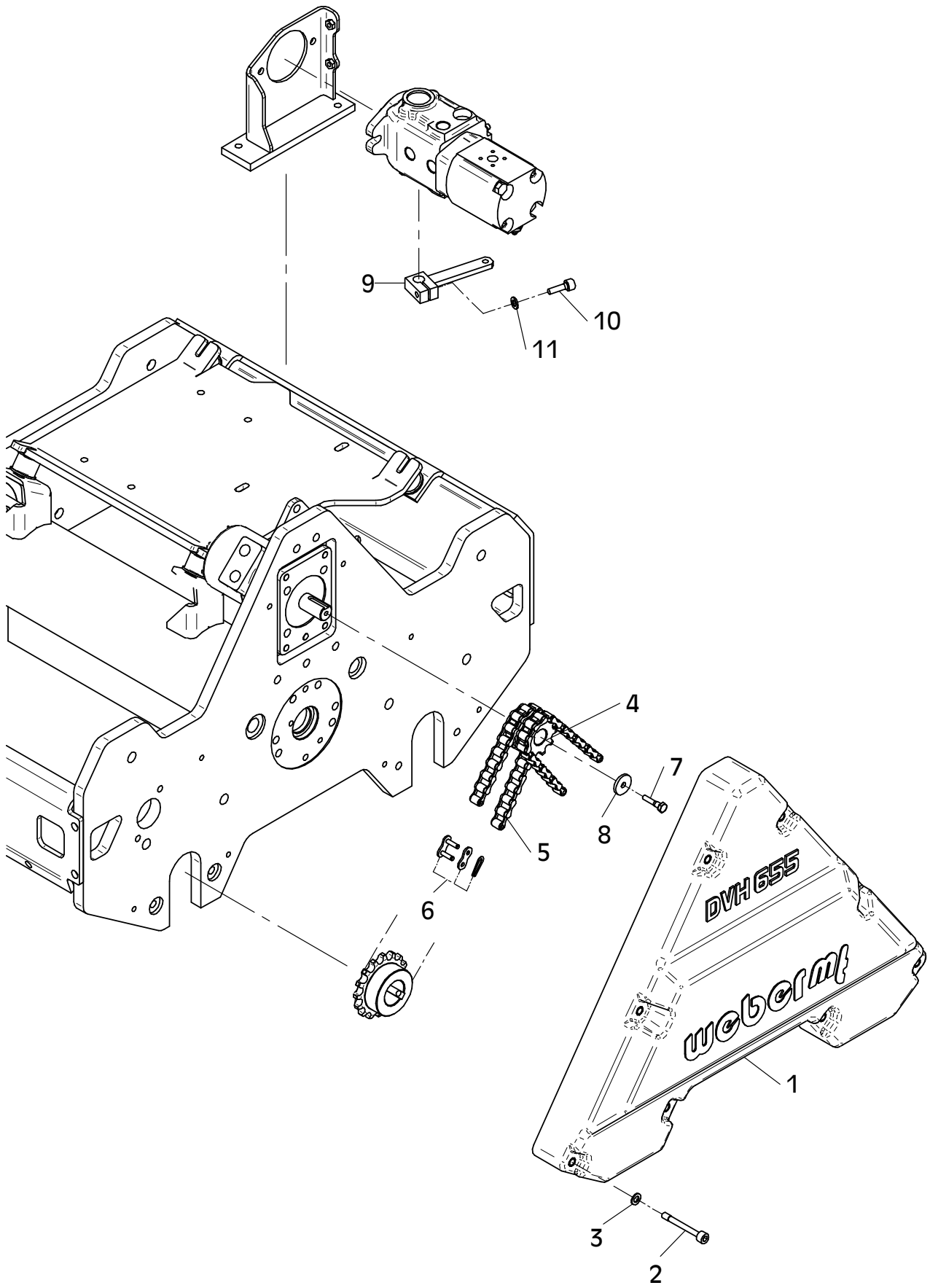

E 3147-0410

E 3148-0504

Position Ref.No. Repère Posizione Posicion	Menge Quantity Quantité Cantidad	Teile-Nr. Part-No. No. Référence Nr. d'Ordine No. Referenzia	Hinweis Hints Indications Indicazione Indicaciones	Position Ref. No. Repère Posizione Posicion	Menge Quantity Quantité Cantidad	Teile-Nr. Part-No. No. Référence Nr. d'Ordine No. Referenzia	Hinweis Hints Indications Indicazione Indicaciones
1	1	10022125					
2	2	25030002	DIN908-M14x1,5				
3	6	25044026	DIN912-M12x35				
4	6	25044035	DIN912-M12x25				
5	12	20025158					
6	4	25036018					
7	1	10001396					
8	2	25025233	DIN988-SS- 80x100x3,5				
9	1	25001142					
10	1	25001141					
11	2	25025161	DIN988-SS-45x55x3				
12	2	25034022	DIN471-A45x1,75				
13	2	10015837					
14	2	20013262					
15	1	25017043					
16	1	20021053					

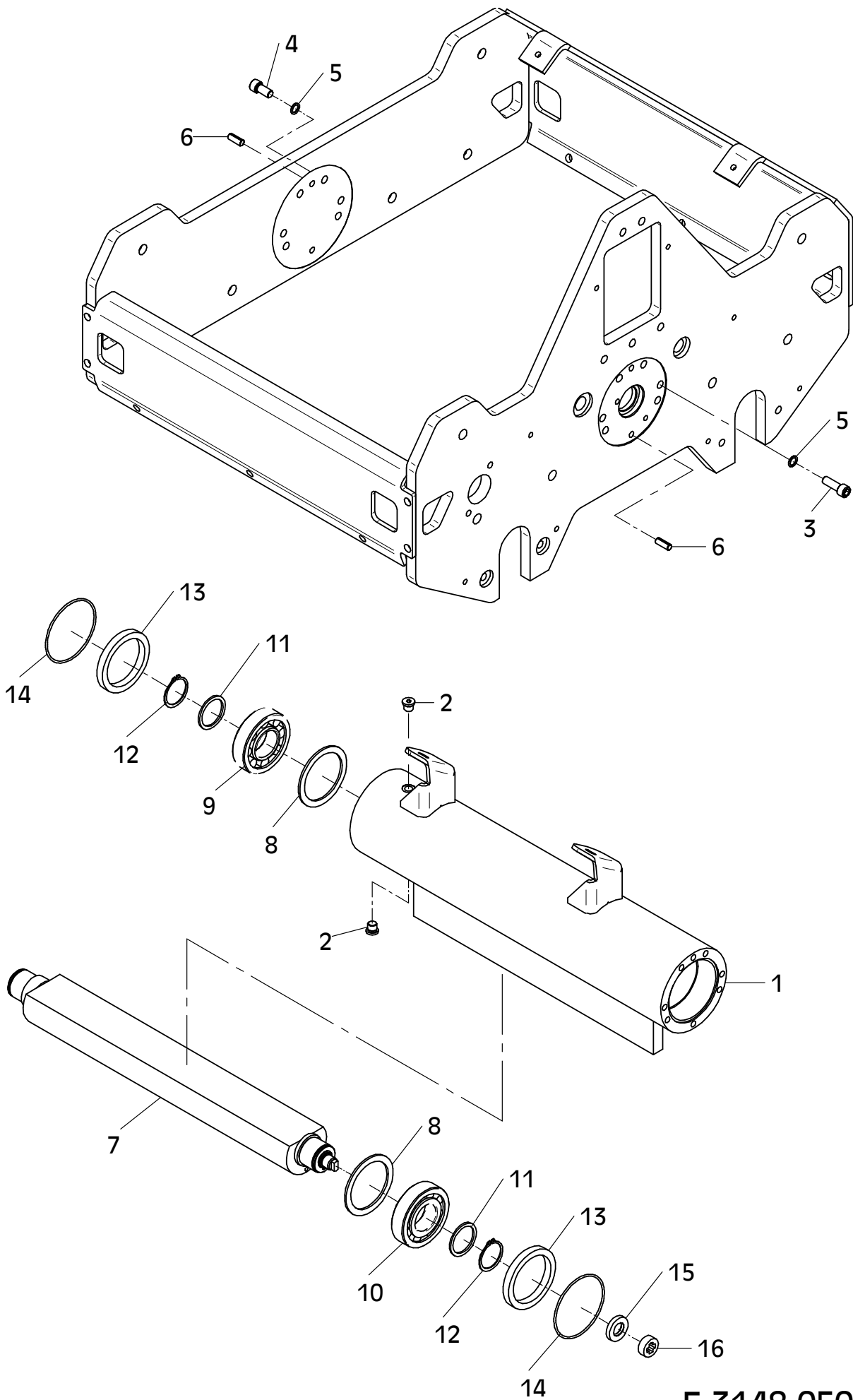

E 3148-0504

E 3149-0812

Position Ref.No. Repère Posizione Posicion	Menge Quantity Quantité Cantidad	Teile-Nr. Part-No. No. Référence Nr. d'Ordine No. Referenzia	Hinweis Hints Indications Indicazione Indicaciones	Position Ref. No. Repère Posizione Posicion	Menge Quantity Quantité Cantidad	Teile-Nr. Part-No. No. Référence Nr. d'Ordine No. Referenzia	Hinweis Hints Indications Indicazione Indicaciones
1	1	20021023					
2	1	25015001					
3	4	25038022	DIN933-M12x40				
4	4	20029004	VSK 12				
5	4	25031005	DIN934-M12				
6	1	20021610					
7	1	10016032					
8	1	25044035	DIN912-M12x25				
9	1	20025158					
10	1	25049040	DIN1441-13x25x3				
11	1	20021083					
12	1	20021619					
13	2	25038008	DIN933-M8x25				
14	2	20029021	SKB 8				
15	1	20021611					
16							
17							
18	1	25015039					
19	2	25038015	DIN933-M10x30				
20	2	25049020	DIN7349-10,5				
21	2	20022003	Tensilock M10				
22	2	21000414	DIN976-M10x105				
23	2	20029025					
24	2	21000415	DIN934-M10				

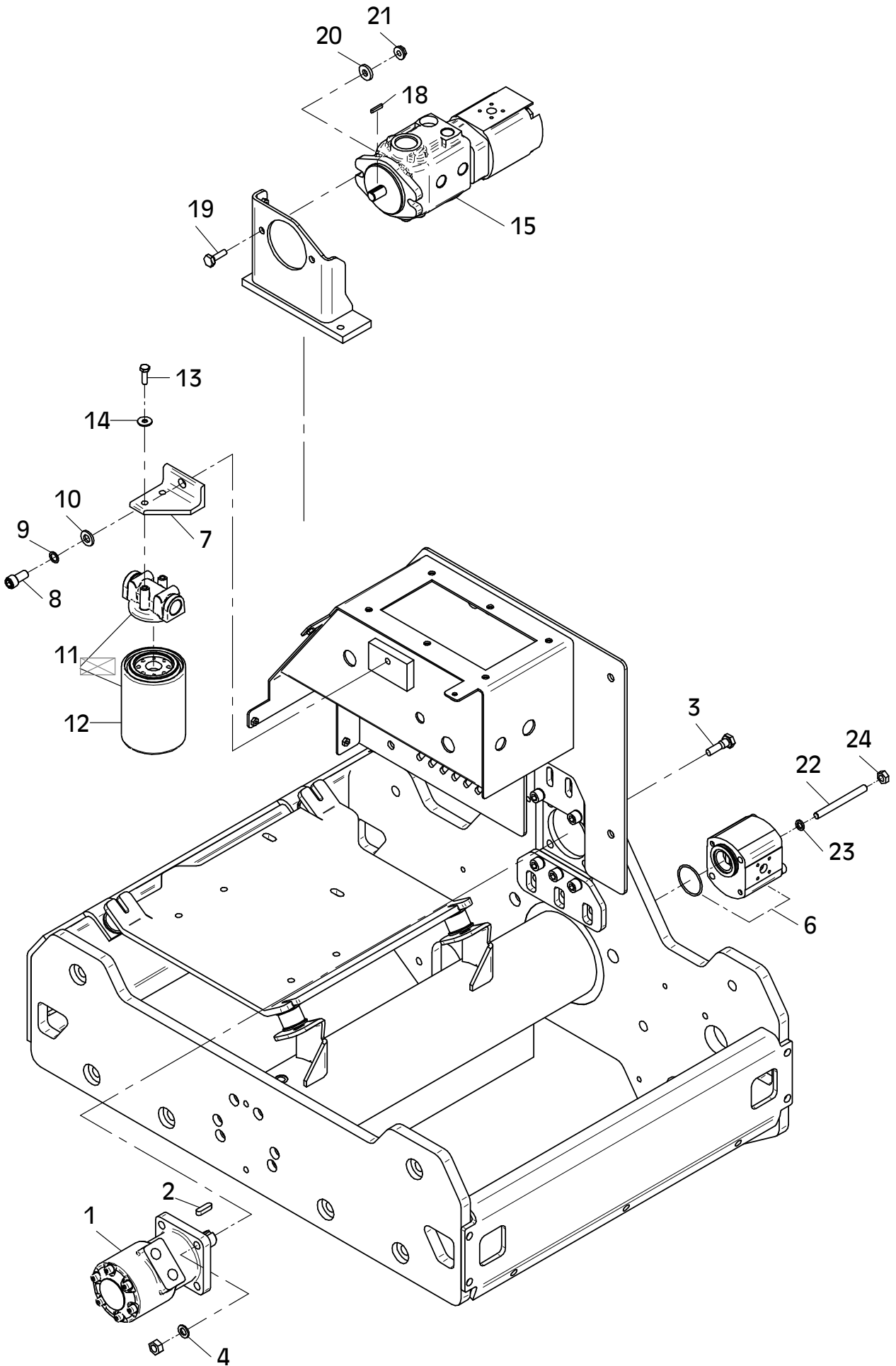

E 3149-0812

E 3150-1112

Position Ref.No. Repère Posizione Posicion	Menge Quantity Quantité Quantità Cantidad	Teile-Nr. Part-No. No. Référence Nr. d'Ordine No. Referenzia	Hinweis Hints Indications Indicazione Indicaciones	Position Ref. No. Repère Posizione Posicion	Menge Quantity Quantité Quantità Cantidad	Teile-Nr. Part-No. No. Référence Nr. d'Ordine No. Referenzia	Hinweis Hints Indications Indicazione Indicaciones
1	4	20020141					
2	1	20020142					
3	2	20020156					
4	2	20020512					
5	1	20016362					
6	1	20016327					
7	1	20020138					
8	1	20020005					
9	1	20016127					
10	1	20020169					
11	1	20020006					
12	1	20020008					
13	1	25033010	DIN431-R3/4"				
14	1	20016337					
15	1	20020039					
16	1	20020157					
17	2	25008019	DIN7603-26x31x2				
18	1	20020467					
19	1	20020046					
20	1	21000768					
21	1	21000766					
22	1	20020076					
23	1	21000767					

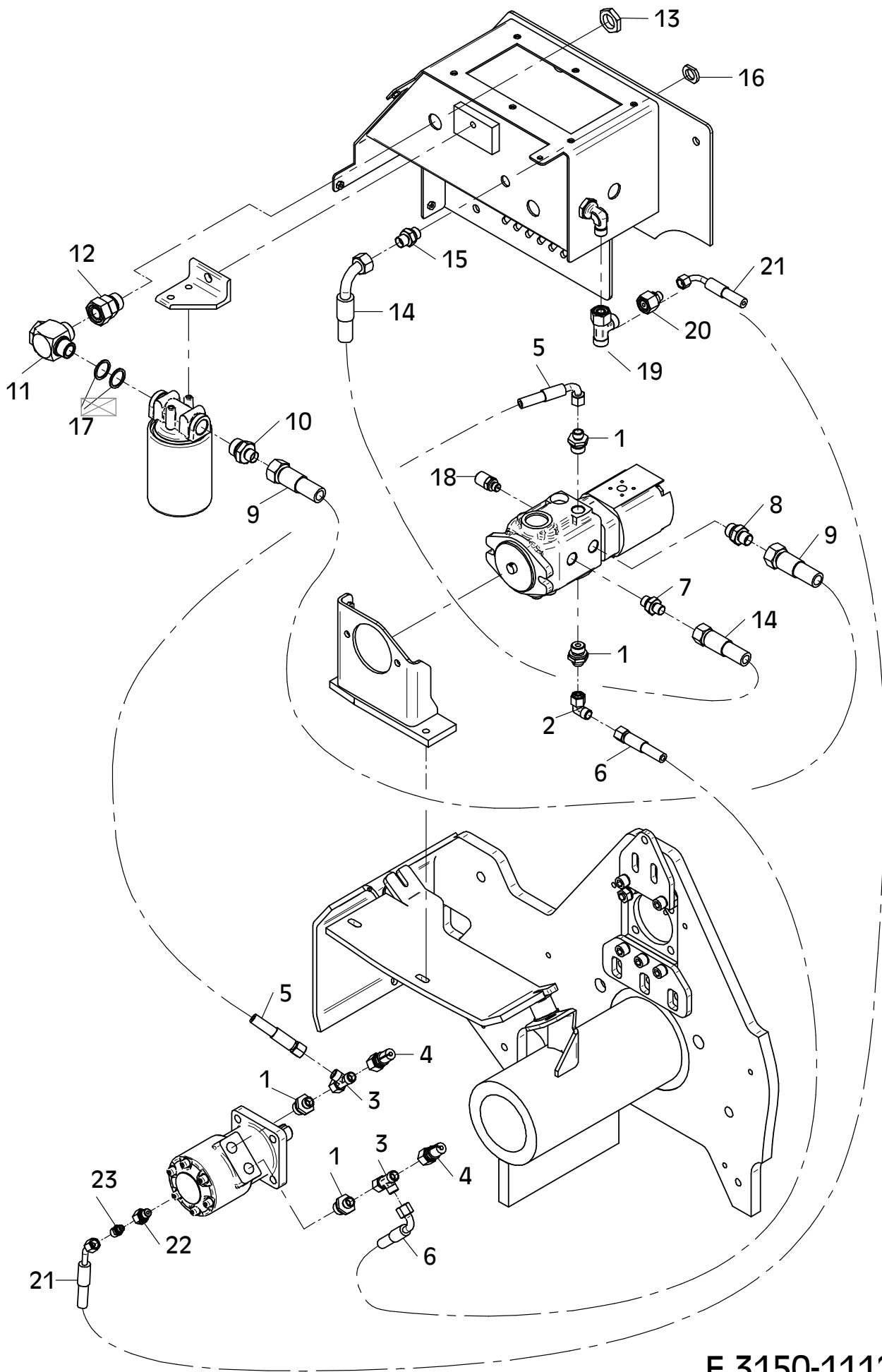

E 3150-1112

E 3151-1112

Position Ref.No. Repère Posizione Posicion	Menge Quantity Quantité Cantidad	Teile-Nr. Part-No. No. Référence Nr. d'Ordine No. Referenzia	Hinweis Hints Indications Indicazione Indicaciones	Position Ref. No. Repère Posizione Posicion	Menge Quantity Quantité Cantidad	Teile-Nr. Part-No. No. Référence Nr. d'Ordine No. Referenzia	Hinweis Hints Indications Indicazione Indicaciones
1	1	20020061		31	3	25048002	DIN125-A8,4
2	1	20020055		32	2	25031003	DIN934-M8
3	1	20020051		33	1	25038075	DIN933-M8x60
4	1	20016329		34	1	20020072	
5	1	20020533		35	1	10015843	
6	1	20020080		36	1	20021606	
7	1	20016116		37	1	10015840	
8	1	20020069		38	2	20029003	VSK 8
9	1	20016328		39	2	25038007	DIN933-M8x20
10	1	20016119		40	2	20025121	
11	1	20020125		41	2	25044003	DIN912-M6x20
12	1	20016336		42	1	20020165	
13	1	20020079					
14	2	20020046					
15	2	20020052					
16	1	20016334					
17	1	20020104					
18	1	25008019	DIN7603-26x31x2				
19	1	20020069					
20	1	25008017	DIN7603-22x27x1,5				
21	1	20020085					
22	1	25033010	DIN431-R3/4"				
23	1	20020003					
24	1	20016335					
25	3	20007201					
26	3	20007080					
27	1	25047038	DIN7991-M8x60				
28	1	20007080					
29	1	25047041	DIN7991-M8x90				
30	2	20007006					

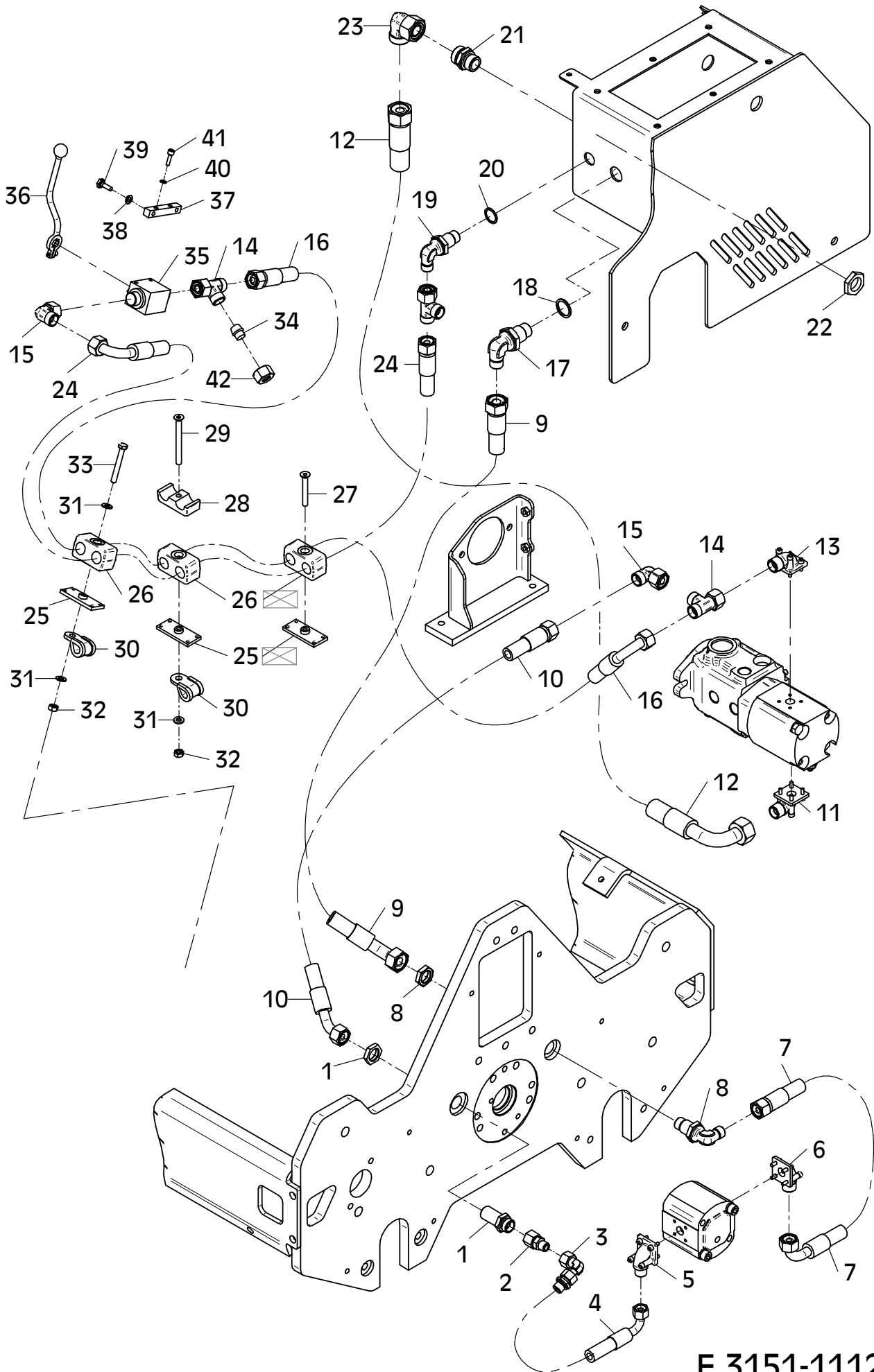

E 3151-1112

E 3152-0306

Position Ref.No. Repère Posizione Posicion	Menge Quantity Quantité Cantidad	Teile-Nr. Part-No. No. Référence Nr. d'Ordine No. Referenzia	Hinweis Hints Indications Indicazione Indicaciones	Position Ref. No. Repère Posizione Posicion	Menge Quantity Quantité Cantidad	Teile-Nr. Part-No. No. Référence Nr. d'Ordine No. Referenzia	Hinweis Hints Indications Indicazione Indicaciones
1	1	21000702		31	1	20022003	Tensilock M10
2	1	20025719		32	1	20007035	
3	2	10008184		33	1	25038013	DIN933-M10x20
4				34	1	25048003	DIN125-A10,5
5	2	10008185		35	1	25031004	DIN934-M10
6							
7	2	25044037	DIN912-M10x55				
8	4	25038007	DIN933-M8x20				
9	4	20029021	SKB 8				
10	1	11000298					
11	5	25038006	DIN933-M8x16				
12	5	20029031	SKM 8				
13	5	10009884					
14	1	20030018					
15	1	25048006	DIN125-A21				
16	1	20030010					
17	1	20007019					
18	1	20016131	0,880 m				
19	1	20007051					
20	1	10001391					
21	1	10001392					
22	1	20016131	0,415 m				
23	2	20007051					
24	2	20025795					
25	1	20007044					
26	1	25038013	DIN933-M10x20				
27	1	25048003	DIN125-A10,5				
28	1	10015787					
29	1	25038014	DIN933-M10x25				
30	1	25048003	DIN125-A10,5				

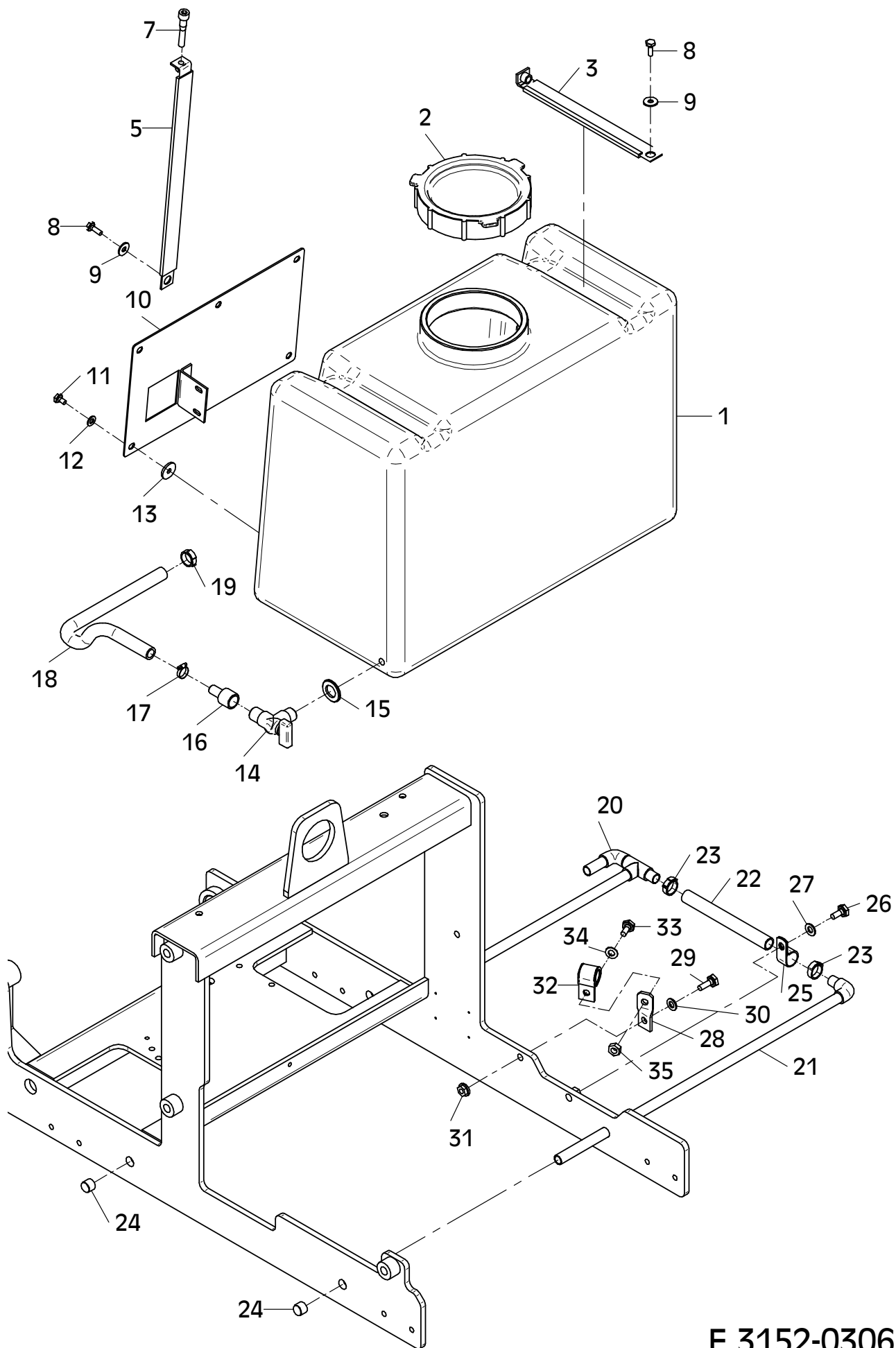

E 3152-0306

E 3153-0411

Position Ref.No. Repère Posizione Posicion	Menge Quantity Quantité Quantità Cantidad	Teile-Nr. Part-No. No. Référence Nr. d'Ordine No. Referenzia	Hinweis Hints Indications Indicazione Indicaciones	Position Ref. No. Repère Posizione Posicion	Menge Quantity Quantité Quantità Cantidad	Teile-Nr. Part-No. No. Référence Nr. d'Ordine No. Referenzia	Hinweis Hints Indications Indicazione Indicaciones
1	1	20031502		31	1	25038015	DIN933-M10x30
2	2	20026531		32	1	25048003	DIN125-A10,5
3	2	25048002	DIN125-A8,4	33	1	20029022	SKB 10
4	1	25038006	DIN933-M8x16	34	1	20022003	Tensilock M10
5	1	20029024		35	1	21000590	
6	1	10001456		36	1	20031532	
7	1	11001818		37	4	21000647	ISO7380-M5x12-10.9
8	1	20007035		38	4	25031023	DIN985-M5
9	1	25038008	DIN933-M8x25	39	1	11001126	
10	1	25048002	DIN125-A8,4	40	1	20031526	10 A
11	1	20022002	Tensilock M8	41	1	21000353	
12	1	20007077		42	1	20016289	0,4 m
13	1	20026471					
14	2	20022002	Tensilock M8				
15	1	10001425					
16	2	25038002	DIN933-M6x16				
17	2	20029020	SKB 6				
18	1	40080599					
19	2	25044100	DIN912-M8x16				
20	2	20029003	VSK 8				
21	2	20022002	Tensilock M8				
22	1	20031532					
23							
24							
25							
26	1	20031541	20 A				
27	1	20025566					
28	2	25038009	DIN933-M8x30				
29	2	20029031	SKM 8				
30	1	11001125					

E 3575-0614

Position Ref.No. Repère Posizione Posicion	Menge Quantity Quantité Quantita Cantidad	Teile-Nr. Part-No. No. Référence Nr. d'Ordine No. Referenzia	Hinweis Hints Indications Indicazione Indicaciones	Position Ref. No. Repère Posizione Posicion	Menge Quantity Quantité Quantita Cantidad	Teile-Nr. Part-No. No. Référence Nr. d'Ordine No. Referenzia	Hinweis Hints Indications Indicazione Indicaciones
1	1	20019006					
2	1	21000741					
3	1	21000856					
4	1	21000857					
5	1	21000047					
6	1	20019376					
7	1	20019377					
8	1	20019007					
9	1	21000474					
10	1	20019418					
11	1	20019397					
12	1	21000313					
13	1	20019357					
14	1	20019410					
15	1	20019097					
16	1	20019281					
17	1	20019104					
18	1	20019118					
19	1	20019401					
20	1	20019002					
21	1	20019003					
22	1	20019322					

Alle Schraubenverbindungen ständig auf festen Sitz überwachen!
 -Besonders nach dem ersten Einsatz-

Continuously check all screwed connections for firm seating
 -particularly after initial employment-

Controler continuellement tous les raccords a vis pour un siege ferme
 -particulierement apres l'emploi initial-

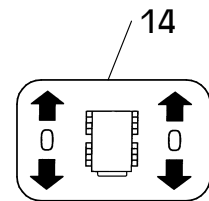
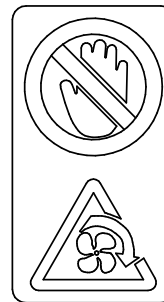
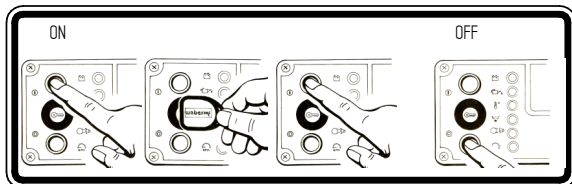
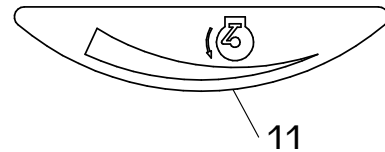
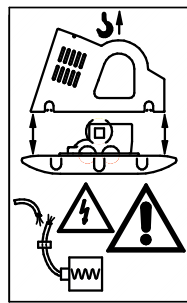
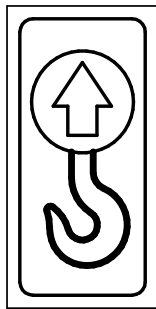
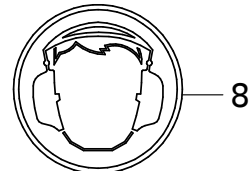
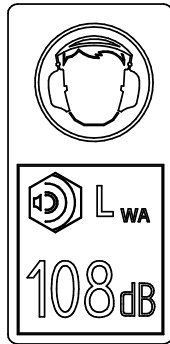
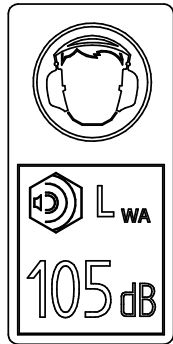
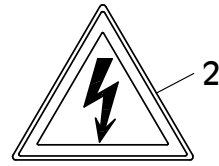

Normalbenzin
Gasoline
Essence

Diesel

Wasser
Water
Eau

HYDRAULIC
OIL

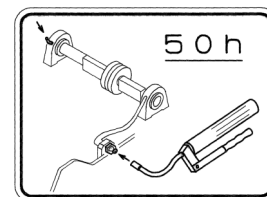
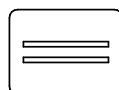
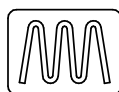
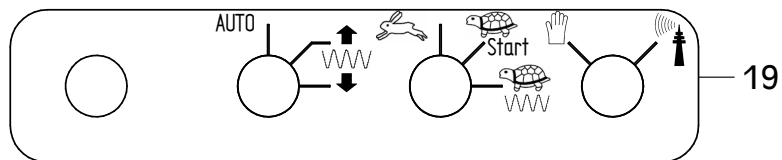

Wenn Sie Fragen, Anregungen, Probleme, usw. haben, wenden Sie sich bitte an eine der unten genannten Adressen:

For problems, questions and further information refer to one of the following addresses:

Si des questions, des suggestions, des problèmes ... survenaient, veuillez vous adresser a l'une des adresses - ci dessous

<p>in Deutschland</p> <p>in Germany</p> <p>Pour l' Allemagne</p>	<p>WEBER Maschinentechnik GmbH Im Boden 5-8 , 10 57334 Bad Laasphe – Rückershausen</p>	<p>Telefon Telefax</p> <p>E-Mail</p>	<p>+ 49 (0) 2754 - 398-0 + 49 (0) 2754 - 398101-Zentrale switchboard Central + 49 (0) 2754 - 398102-Ersatzteil-Direktlinie spare parts-directlinie Ligne direct pièces détachées</p> <p>g.voelkel@webermt.de</p>
<p>in Frankreich</p> <p>in France</p> <p>Pour la France</p>	<p>WEBER Technologie SARL 26' rue d' Arsonval 69680 Chassieu</p>	<p>Telefon Telefax</p> <p>E-Mail</p>	<p>+ 33 (0) 472 - 791020 + 33 (0) 472 - 791021</p> <p>france@webermt.com</p>
<p>in Polen</p> <p>in Poland</p> <p>Pour la Pologne</p>	<p>WEBER Maschinentechnik Sp. zo.o. Ul. Grodziska 7 05-830 Stara Wies</p>	<p>Telefon Telefax</p> <p>E-Mail</p>	<p>+ 48 (0) 22 - 739 70 - 80 + 48 (0) 22 - 739 70 - 81 + 48 (0) 22 - 739 70 - 82</p> <p>info@webermt.com.pl</p>
<p>in Tschechien</p> <p>in Czechia</p> <p>Pour la Tchéquie</p>	<p>WEBER MT s.r.o. V Piskovně 2054 278 01 Kralupy nad Vitavou</p>	<p>Telefon</p> <p>E-Mail</p>	<p>+ 42 (0) 776 222 216 + 42 (0) 776 222 261</p> <p>info@webermt.cz</p>
<p>in USA und Kanada</p> <p>in USA und Canada</p> <p>Pour les Etats Unis Et le Canada</p>	<p>WEBER MT, Inc. 45 Dowd Road Bangor, ME 04401</p>	<p>Telefon Telefax</p> <p>E-Mail</p>	<p>+ 1(207) - 947 - 4990 + 1(207) - 947 - 5452</p> <p>sales@webermt.com service@webermt.com</p>
<p>in Süd – Amerika</p> <p>in South – America</p> <p>Pour l' Amérique du sud</p>	<p>WEBER Maschinentechnik do Brasil Rua João Werno Erhart, 4691 Bairro Rição 93310 – 405 Novo Hamburgo / RS Brasilien</p>	<p>Telefon Telefax</p> <p>E-Mail</p>	<p>+ 55 (0) 51- 587 3044 + 55 (0) 51- 587 2271</p> <p>webermt@webermt.com.br</p>

