

APF 20/50

FORWARD MOVING VIBRATORY PLATES

HONDA



HATZ



PACKING POWER

The APF 20/50 provides the most power in the new APF lineup. It features a working width of 500 mm and centrifugal force of 18 kN. The plate's technologically advanced exciter unit is completely maintenance free. The exciter system also provides significant forward-moving power to enhance productivity in challenging materials and on steep grades. The APF 20/50 Honda has an engine output of 3.7 kW (5 HP), the most power in the new APF lineup. The APF 20/50 Hatz combines all the benefits of other Ammann plates with a diesel engine that makes fueling at the jobsite more convenient. The diesel engine provides engine power of 3.2 kW (4.3 HP) and also excels in higher altitudes.

SIMPLE OPERATION

- Operator safety with low HAV levels on the handle
- Machine frame that enables secure grip
- Great maneuverability boosts accuracy and makes work simple

POWERFUL COMPACTOR

- Generously sized, powerful exciter unit
- Leading compaction power, speed, climbing ability and machine life
- Compact dimensions allow use on sites with limited space

READY FOR RENTAL

- Low cost upkeep for owners
- Good match for many applications
- Easy for new users to operate

SERVICEABILITY

- Maintenance-free exciter system
- Full engine protection frame
- Toolless daily maintenance

VERSATILE OPTIONS

- Toolless mountable water tank and sprinkler system
- Toolless mountable rubber mats to change onto paving stones
- Permanently mounted transport wheels easy relocation of the machine on site

APPLICATIONS

- Compaction in confined areas
- Asphalt and paving applications
- Light to medium patchwork
- Pipeline and trench construction
- Landscaping and gardening
- Earthwork

AMMANN

TECHNICAL SPECIFICATIONS
 APF 20/50
 FORWARD MOVING
 VIBRATORY PLATES

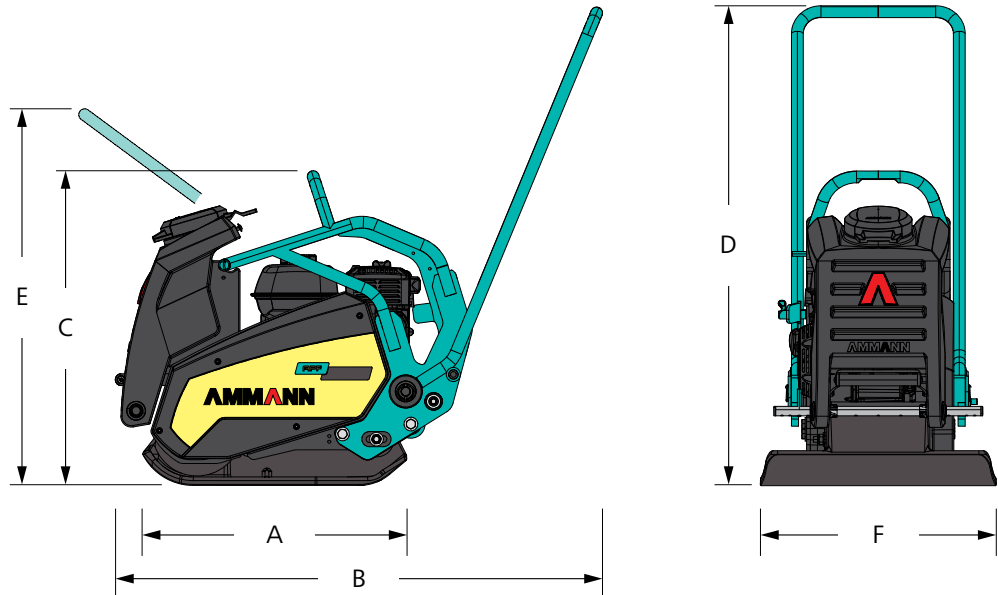

DIMENSIONS & WEIGHTS

	Honda	Hatz
MACHINE WEIGHT	88 kg (194 lb)	106 kg (234 lb)
A BASE PLATE LENGTH	346 mm (13.62 in)	352 mm (13.86 in)
B MACHINE LENGTH	1032 mm (40.62 in)	1164 mm (45.83 in)
C MACHINE HEIGHT	529 mm (20.82 in)	673 mm (26.50 in)
D WITH HANDLE (WORK)	1015 mm (39.96 in)	1015 mm (39.96 in)
E WITH HANDLE (TRANSPORT)	860 mm (33.86 in)	738 mm (29.06 in)
F MACHINE WIDTH	500 mm (19.7 in)	500 mm (19.7 in)

COMPACTION FORCES

	Honda	Hatz
MAX. VIBRATION FREQUENCY	90 Hz (5400 vpm)	90 Hz (5400 vpm)
MAX. CENTRIFUGAL FORCE	20 kN	20 kN
WORKING SURFACE	up to 1020 m ² /h	up to 870 m ² /h
SPEC. SURFACE PRESSURE	8.1 N/cm ²	9.0 N/cm ²

ENGINE

	Honda	Hatz
ENGINE	Honda GX 160	Hatz 1B20
FUEL	Petrol	Diesel
ENGINE OUTPUT AT RPM	3.7 kW (5 HP) 3250	3.2 kW (4.3 HP) 3250

MISCELLANEOUS

WORKING SPEED	3.1 m/s ²	<2.5 m/s ²
MAX. GRADEABILITY	0–27 m/min (88.6 fpm)	0–27 m/min (88.6 fpm)
MAX. INCLINE	30 %	30 %
MAX. INCLINE	20°	20°

OPTIONS

RUBBER MAT	x	x
TRANSPORT WHEELS	x	x
WATER SPRINKLER SYSTEM	10 l	10 l
HOUR METER	x	x

HIGHLIGHTS

- Low-vibration handle for operator safety and comfort
- Maintenance-free exciter system
- Base plate that is self cleaning and wear resistant
- Engine frame for protection on the jobsite and during transport
- Transport wheels, which can be dropped with a foot release and enable mobility on the jobsite