

Operating Manual

HPP09E Hydraulic Powerpack

From serial
number 13885

Revised
22.11.2018

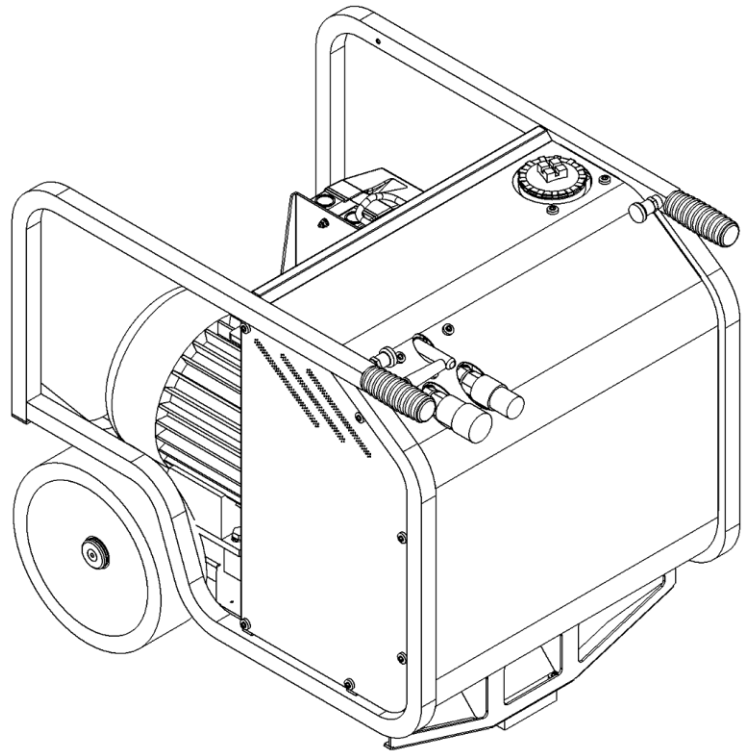

Prior to Operation

We thank you for choosing a HYCON powerpack.

Please note that the powerpack is delivered without hydraulic oil, and therefore it must be filled up with hydraulic oil prior to operation.

To ensure smooth operation and long-lasting performance of your new powerpack, we recommend you to study this operating manual carefully and pay special attention to the

Safety and Service Precautions

We hope you will be satisfied with your new HYCON powerpack.

Best regards
HYCON A/S



HYCON A/S
Juelstrupparken 11
DK-9530 Støvring
Denmark

Tel: +45 9647 5200
Fax: +45 9647 5201
Mail hycon@hycon.dk
www.hycon.dk

Contents

	Page
Safety precautions.....	2
Filling up hydraulic oil	3
Technical data.....	4
Electrical Circuit Diagram	5
Starting instructions	6
Service, maintenance and hydraulic settings	7
Oil types	8
EC-Declaration of Conformity	9
Warranty conditions	10
Spare parts list.....	11

Safety Precautions



DANGER: The power pack must only be connected to an electrical power source with the correct fuse and fault current protection. If this is not observed, there is a risk of major personal injury or, in extreme consequence, death due to electric shock.



IMPORTANT: Read and follow this operating manual carefully to avoid personal injury and damage to the power pack.

1. Always use protective earplugs. The powerpack complies with the EU noise limits, but by daily long-lasting operation there is a risk of hearing defects.
2. Always connect hoses before starting.
3. Always keep the electric box, cables and sockets clean.
4. Always connect the powerpack to a power source with the correct electrical protection.
5. Always turn of the motor and disconnect the power supply when the power pack not used and before performing any service.
6. Never start the motor without side covers.
7. Operation of the powerpack without tool connected and with lever at "ON" may cause overheating of the system and damage to the powerpack.
8. When lifting the powerpack from a vehicle, we recommend the use of a crane.
9. The pressure relief valve is set at 150 bar from our plant. Never set it higher.
10. Always use filters with by-pass. The use of filters without by-pass may blow the hydraulic hoses and the filter cover.

Filling Up Hydraulic Oil

- To fill up with hydraulic oil, loosen the filter cover on top of the powerpack.
- Remove the filter element (see photo), and fill up with oil. When oil is showing at the bottom of the filter unit, there is enough oil on the powerpack.
- Insert the filter element again, mount the cover and the powerpack is ready for use.

Please note: When connecting new extension hoses, it is necessary to fill up with extra 2 litres of oil. Therefore always top up the powerpack when connecting new extension hoses.



Technical Data

Hydraulics

The HYCON HPP09E open centre hydraulic powerpack is designed in accordance with the EHTMA category C, which prescribes a minimum performance of 20 l.p.m. at 138 bar. The HYCON powerpack is fully compatible with and sufficient for the common European tools.

The powerpack is mounted with a pressure relief valve to avoid a too high pressure. Furthermore, the very efficient air cooling protects the powerpack against super-heating.

Oil flow	20 l.p.m at 2950 r.p.m.
Working pressure nominal	120 bar
Pressure relief valve	Set at 150 bar
Pump	Gear pump
Oil temperature	Max. 70° C
Hydraulic oil tank capacity	Min. 6 litres/max. 8 litres
Hydraulic system compl.	Max. 9 litres
Filter system (filter element)	25 Micron with by-pass
Motor	Electric motor 5.5 kW, 3x400 V, 50 Hz Motor and electric box approved for IP55
Motor rotation	Clockwise (seen from the back)
Fuse minimum	16 Amp
Guaranteed sound power level L_{WA}	97 dB
Sound pressure level 1 m L_{PA}	85 dB
Dimensions (LxWxH)	710x550x645 mm
Weight, without hydraulic oil	84 kg

Electrical Circuit Diagrams

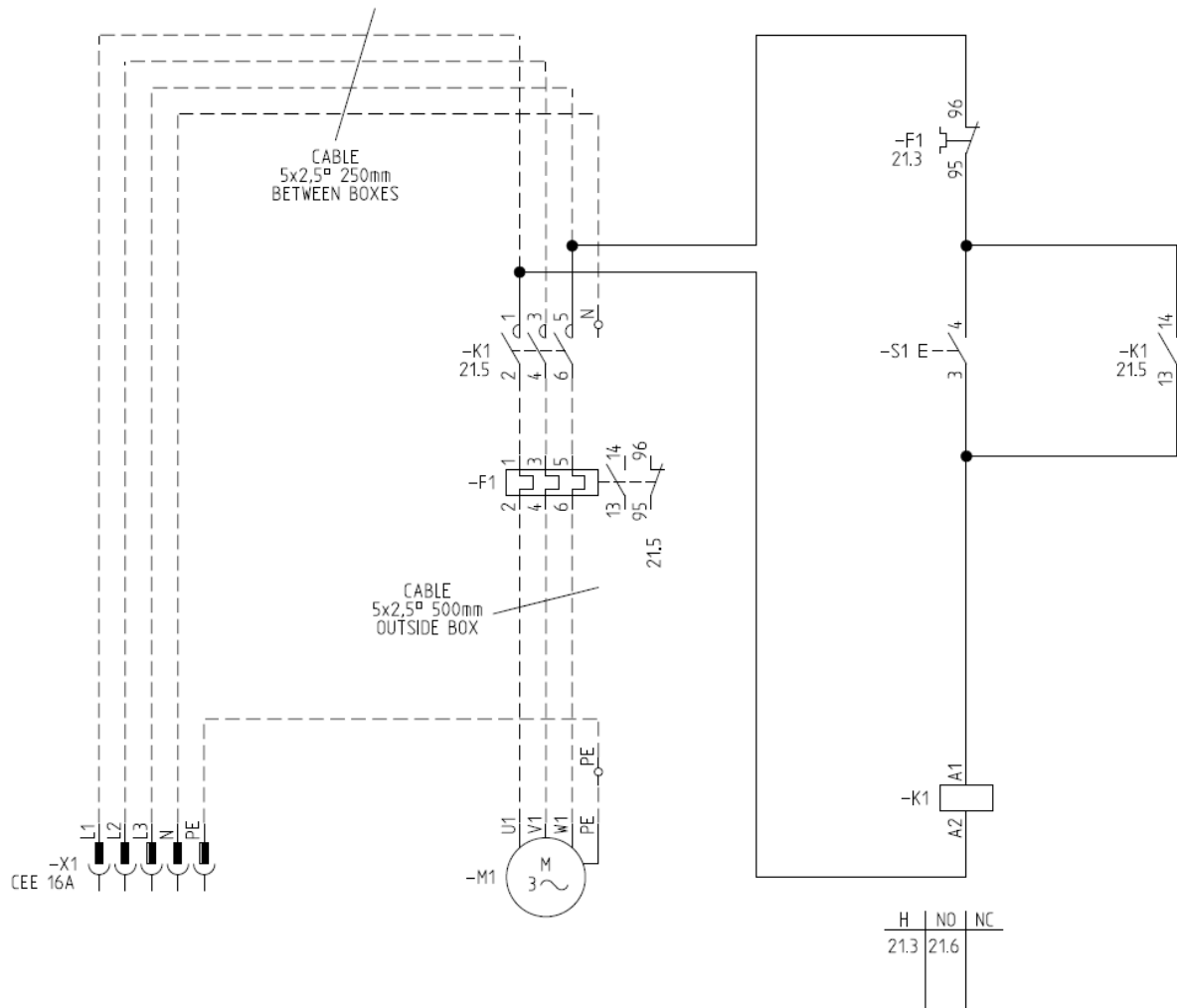

Starting Instructions

Please observe the starting instructions on the electro box.

- Start:**
- Check hydraulic oil level at sight glass
 - Connect hoses and tool
 - Press the green button
 - If the motor's direction of rotation is wrong, invert the phases in the socket by means of a screw driver
 - Move the lever to "ON"

- Stop:**
- Move the lever to "OFF"
 - Press the "STOP" button

The powerpack is not equipped with an automatic phase inverter. If the motor's direction of rotation is wrong, the phases must be inverted in the socket by means of a screw driver. Also see above under "Start".

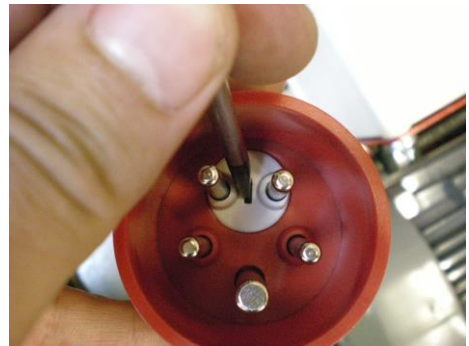

Motor's Direction of Rotation: Clockwise (seen from the back)

Service, Maintenance and Hydraulic Settings

Service/Maintenance	Daily	Weekly	Yearly
Engine oil	Check		1 x replacement
Hydraulic oil	Check		1 x replacement
Hydraulic oil filter *)			1 x replacement
Check hoses		(tighten up if needed)	
Air filter			1 x replacement
Fuel filter			1 x replacement

*) Use only filters with by-pass

Hydraulic Settings

Check the working pressure by means of test equipment. The test equipment must comprise a pressure gauge, a flow meter and a valve for adjustment of pressure.

The pressure relief valve is placed on the right side of the valve block.

1. Connect the test equipment, start the powerpack and move the lever to "ON". Then close the flow valve - the pressure gauge must show 150 bar.

Adjust the pressure relief valve by loosening the lock nut and turning the adjustment screw in or out. "In" increases the pressure, and "out" decreases the pressure.

Retighten the lock nut after adjustment.

2. When the pressure relief valve has been adjusted correctly, the working pressure must be set at 100 bar by means of the valve on the test equipment. At 100 bar, the oil flow should be 20 l. p.m.

If correct pressure/oil flow cannot be achieved by following the above instructions, the powerpack must be re-adjusted. If the pressure/oil flow is then still incorrect, the pump is defect and must be replaced.

Oil Types

The HYCON power packs use standard hydraulic oil, i.e. all types of mineral oil and biodegradable oil, which comply with the following values:

Ambient temperature range	Below 10°C 50°F	10 ... 30°C 50 ... 68°F	Above 30°C 68°F
Recommended oil viscosity grade	VG 32	VG 46	VG 68

Recommended oil cleanliness		ISO 4406 /19/16 / NAS 1638 10
Permitted viscosity	cSt	10 – 600
Viscosity index	Minimum	100
Oil temperature area	°C /°F	-20 to 70 / -4 to 158

EC-Declaration of Conformity



HYCON A/S
Juelstrupparken 11
DK-9530 Støvring
Denmark

Tel: +45 9647 5200
Fax: +45 9647 5201
Mail hycon@hycon.dk
www.hycon.dk

We hereby declare that

HPP09E hydraulic powerpack – from serial No. 13885
(with 5.5 kW electric motor)

is manufactured in conformity with the EC Directives:
2006/42/EC
2000/14/EC
2006/95/EC

Notified Body 1585:

AkustikNet A/S
Frederikssundsvej 179 B
DK-2700 Brønshøj
Denmark

Guaranteed sound power level: 97 dB

HYCON A/S
Juelstrupparken 11
DK-9530 Støvring
Denmark

A handwritten signature in blue ink, appearing to read "Martin Møller".

Martin Møller
Managing Director

24.08.2018

Warranty Conditions

We grant 12 months warranty from the first date of operation – however, not more than 18 months from the date of delivery.

The warranty applies to faults that can be related to construction and production errors.

Faults caused by incorrect operation, incorrect handling, lack of maintenance or the like will not be accepted as warranty.

The warranty covers the parts necessary for repair and the suggested average time needed for repair.

For further warranty details, please contact your local dealer.